

Configuration spaces from Combinatorial, Topological and Categorical perspectives

M.A.Batanin, Macquarie University

September 27, 2006

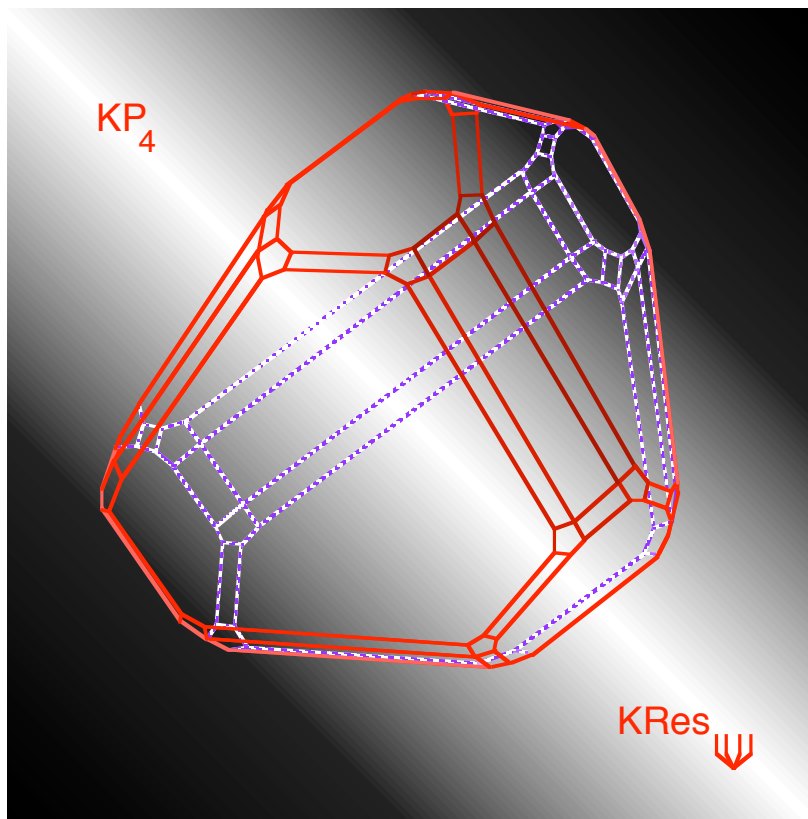

After all, the most mysterious aspect of n -category theory is the origin of coherence laws.

John Baez, "Categorification" (1998)

Contents

1	Coherence laws as a source of equations	3
2	1-fold loop spaces and associahedra	8
3	Double loop spaces and low dimensional coherence laws	16
4	Operads	17
5	Fulton-Macpherson compactification	21
6	n -ordinals as n -dimensional natural numbers	28
7	n -operads	31
8	Stratification, compactification and higher dimensional coherence laws	33
9	n -operadic compactification	41
10	The Table of coherence laws	45

1 Coherence laws as a source of equations

Let L be a vector space over k equipped with a skew-symmetric bilinear operation

$$[-, -] : L \times L \rightarrow L.$$

Let $V = k \oplus L$. Define the isomorphism

$$B : V \otimes V \rightarrow V \otimes V$$

by

$$B((a, x) \otimes (b, y)) = (b, y) \otimes (a, x) + (1, 0) \otimes (0, [x, y]).$$

Then $[-, -]$ satisfies the

Jacobi identity

if and only if B makes the following diagram commutative:

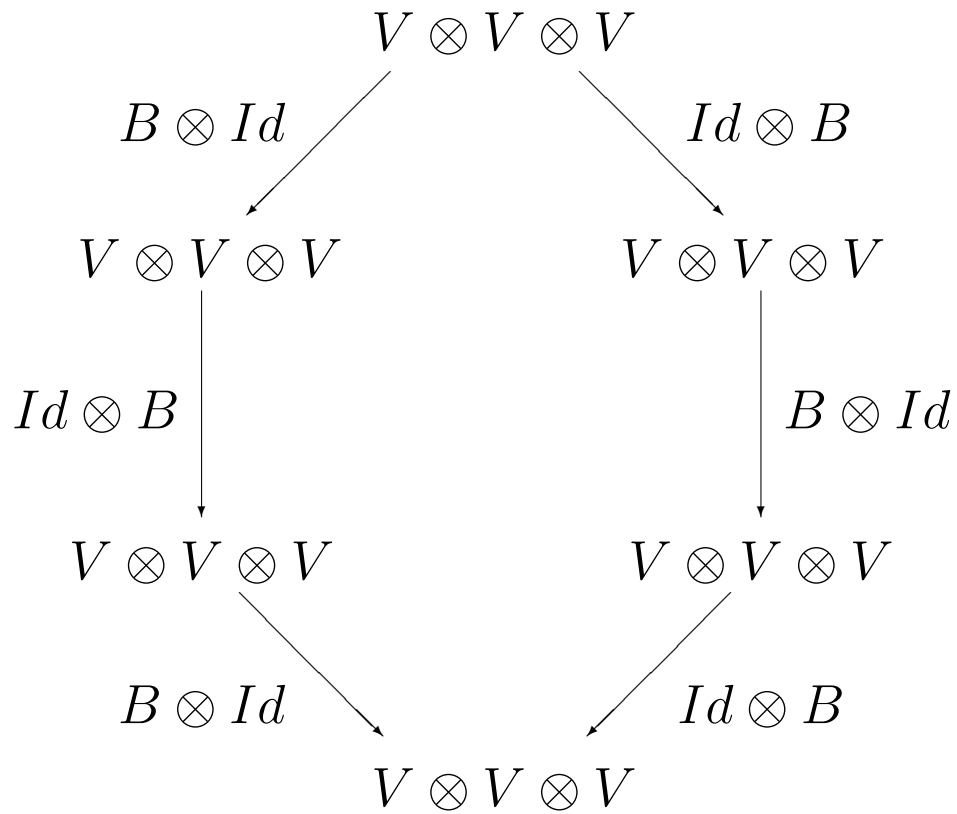

Yang-Baxter Equation

Eilenberg, MacLane, Steenrod, Whitehead

1930-1950 :

- 3-cocycle equation in group cohomology in algebra;
MacLane's pentagon and hexagon conditions in category theory.

- the theory of cohomology and homotopy operations in algebraic topology.

1950-1970th:

- A_∞ -spaces and A_∞ -algebras; delooping machines, homotopy invariant algebraic structures, the theory of operads in homotopy theory and algebraic topology by **Stasheff, Boardman-Vogt, Milgram, Segal, May** .

Since the 1980s the equations determined by coherence laws have proliferated in many different fields of Mathematics and Physics. Examples include:

- *Topology*: homotopy theory, algebraic topology, knot theory;
- *Quantum algebra* : Yang-Baxter equations and Kniznik-Zamolodchikov equations ;
- *Algebra and Algebraic Geometry*: Theory of generalised determinants, theory of gerbes, non-Abelian cohomology;
- *Combinatorics*: the theory of hyperplane arrangements;
- *Mathematical Physics*: A_∞ -categories, mirror symmetry conjecture, String Theory;
- *Noncommutative Geometry*: Deformation Quantisation.
- *Category Theory*: braided monoidal categories and higher dimensional categories;

There is an urgent need of

a Coherent Theory of Coherence Laws

for higher dimensional algebraic structures! Coherence laws for n -fold loop spaces should form the foundations for such a Theory.

Most notable theories are:

- The theory of homotopy invariant algebraic structures of Boardman and Vogt;
- The Koszul duality theory for operads by Guinzburg and Kapranov;
- Kontsevich and Soibelman recent approach through formal noncommutative geometry.

The ultimate solution should describe the combinatorics of coherent laws and explain its origin in geometry. And here the only approach succeeding in all ways was proposed by **Stasheff** in **1963** for the coherence of 1-fold loop spaces.

The main purpose of this lecture is to explain how we can extend Stasheff's theory for $n > 1$.

2 1-fold loop spaces and associahedra

Let (X, a) be a pointed topological space. The loop space ΩX is the space of continuous maps

$$\phi : [0, 1] \rightarrow X$$

with compact-open topology such that

$$\phi(0) = \phi(1) = a.$$

Multiplication (composition of paths)

$$\mu_2 : \Omega X \times \Omega X \rightarrow \Omega X$$

$$\mu_2(\phi, \psi)(t) = \phi \cdot \psi(t) = \begin{cases} \phi(2t) & \text{if } 0 \leq t \leq 1/2 \\ \psi(2t - 1) & \text{if } 1/2 \leq t \leq 1 \end{cases}$$

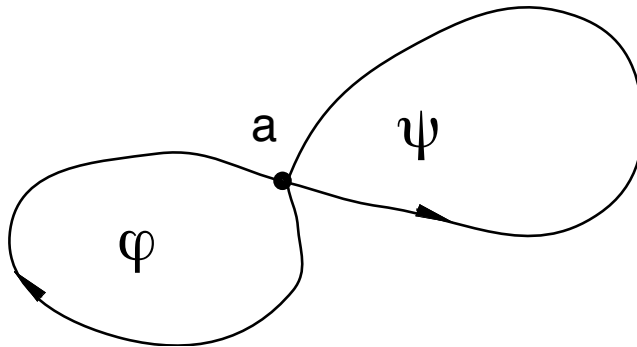

Multiplication is not associative, but it is **homotopy associative**. The **homotopy** (continuous deformation) from the path

$$(\phi \cdot \psi) \cdot \omega$$

to the path

$$\phi \cdot (\psi \cdot \omega)$$

is given by

$$\mu_3 : K_3 \times (\Omega X)^3 \rightarrow \Omega X$$

$$K_3 = [0, 1]$$

and satisfies

$$\mu_3(0, -, -, -) = \mu_2(\mu_2(-, -), -)$$

and

$$\mu_3(1, -, -, -) = \mu_2(-, \mu_2(-, -)).$$

$$\mu_3(\phi, \psi, \xi)(w, t) =$$

$$= \begin{cases} \phi((4-2w)t) & \text{if } 0 \leq t \leq 1/(4-2w) \\ \psi(4t - (1+w)) & \text{if } 1/(4-2w) \leq t \leq 1/4 + 1/(4-2w) \\ \xi((1+w)(2t - (4-w)/(4-2w))) & \text{if } 1/4 + 1/(4-2w) \leq t \leq 1 \end{cases}$$

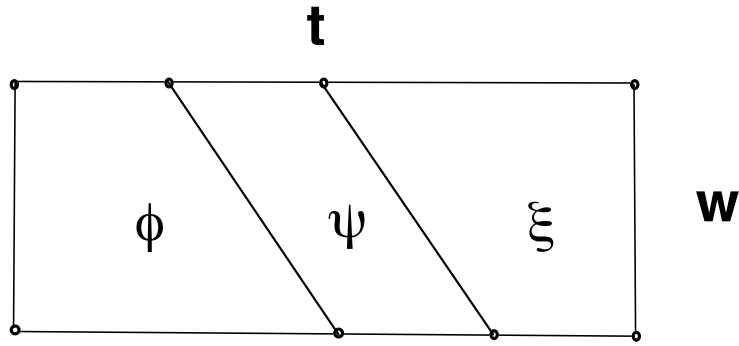

2-homotopy (2-dimensional deformation)

$$\mu_4 : K_4 \times (\Omega X)^4 \rightarrow \Omega X$$

K_4 is a pentagon.

$$S^1 \times (\Omega X)^4 = \partial K_4 \times (\Omega X)^4 \rightarrow \Omega X$$

is constructed from compositions of μ_2, μ_3 :

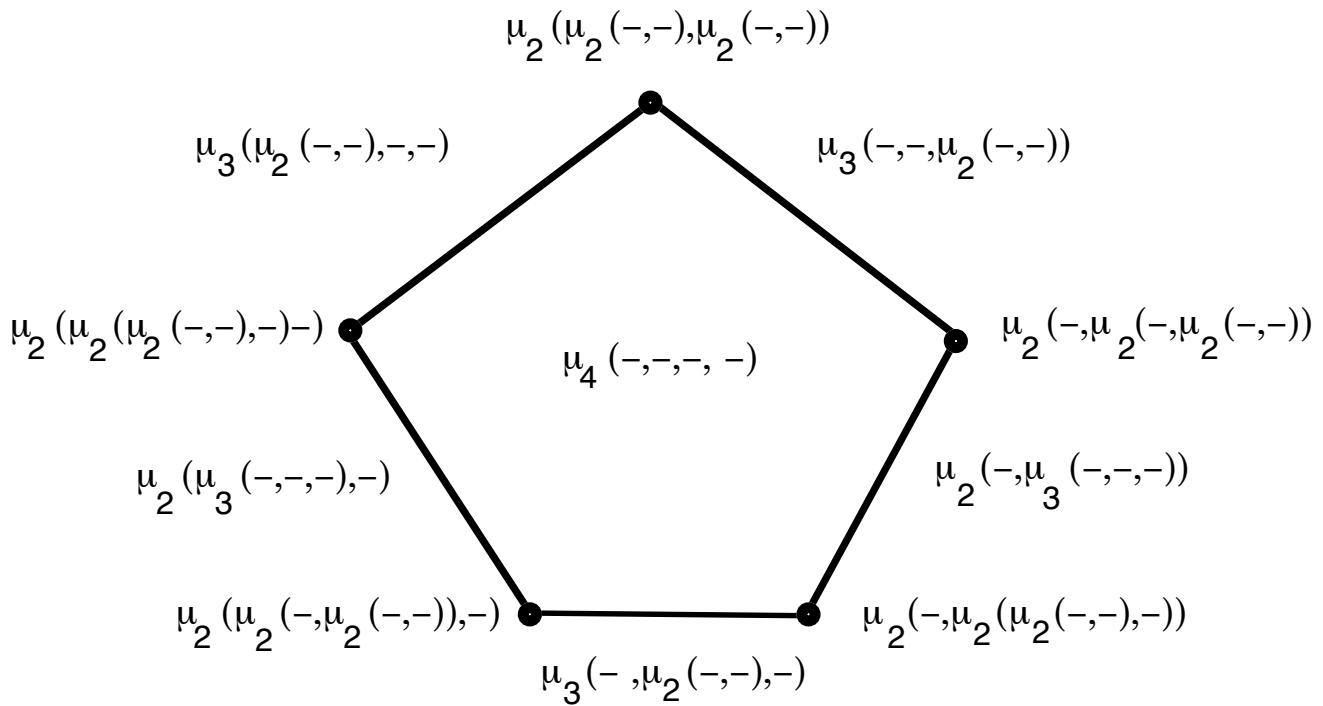

Theorem 2.1 (Stasheff 1963) *There exists a sequence of polytopes K_n , $n \geq 0$, such that K_n is homeomorphic to a ball of dimension $(n - 2)$ and a sequence of continuous maps*

$$\mu_n : K_n \times (\Omega X)^n \rightarrow \Omega X$$

with the following properties:

1. *the faces of K_n correspond to the planar trees with n -leaves. In particular, the vertices of K_n correspond to the binary trees with n -leaves i.e. to all possible bracketings of a string with n -symbols;*
2. *the boundary sphere ∂K_n is subdivided to the facets homeomorphic to the products*

$$K_p \times K_q, \quad p + q = n + 1 ;$$

3. *it is possible to construct a map*

$$\partial K_n \times (\Omega X)^n \rightarrow \Omega X$$

using different compositions of μ_k , $k < n$, such that μ_n is an extension of this map to K_n .

Theorem 2.2 (Stasheff 1963) *A connected base space Y (with strict unit) is a loop space (i.e. Y is homotopy equivalent to ΩX for some X) if and only if there exists a sequence of operations*

$$\mu_n : K_n \times Y^n \rightarrow Y$$

such that the restriction of μ_n to the boundary of K_n is constructed like in (3).

Such a space is called **A_∞ -space** by Stasheff. The polytope K_n is **the n -th associahedron** (1980s).

This theorem led directly to the modern theory of operads.

The first three nontrivial associahedra

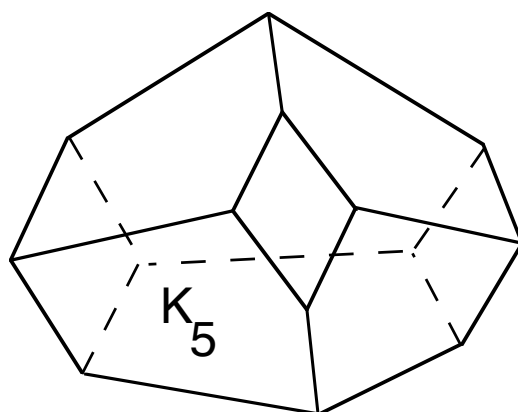
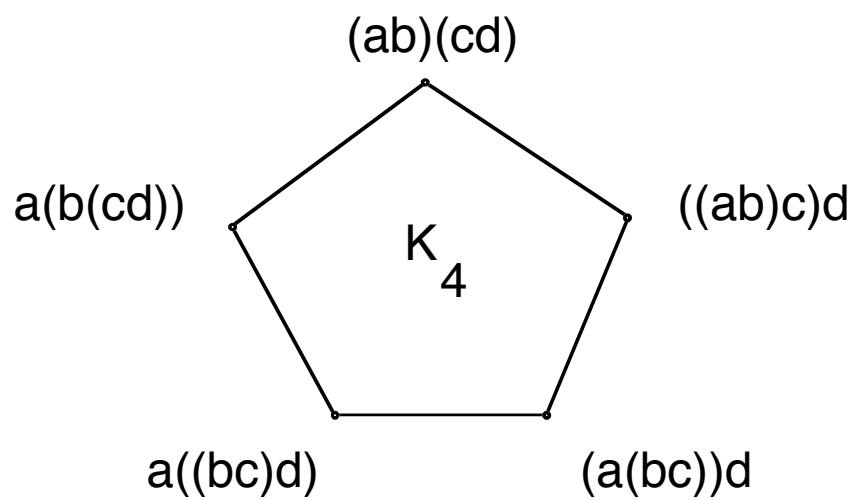
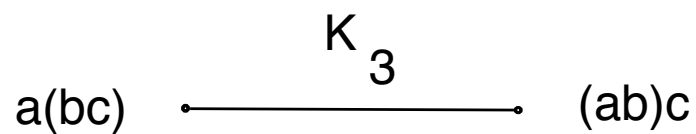

Loday's convex realisation of associahedra.

The convex polytope defined by the following system of inequalities

$$x_1 + \dots + x_{n-1} \leq n(n-1)/2$$

$$x_i + \dots + x_{i+k-1} \geq k(k+1)/2$$

$$1 \leq i \leq n-1, 1 \leq k \leq n-i$$

is combinatorially isomorphic to K_n .

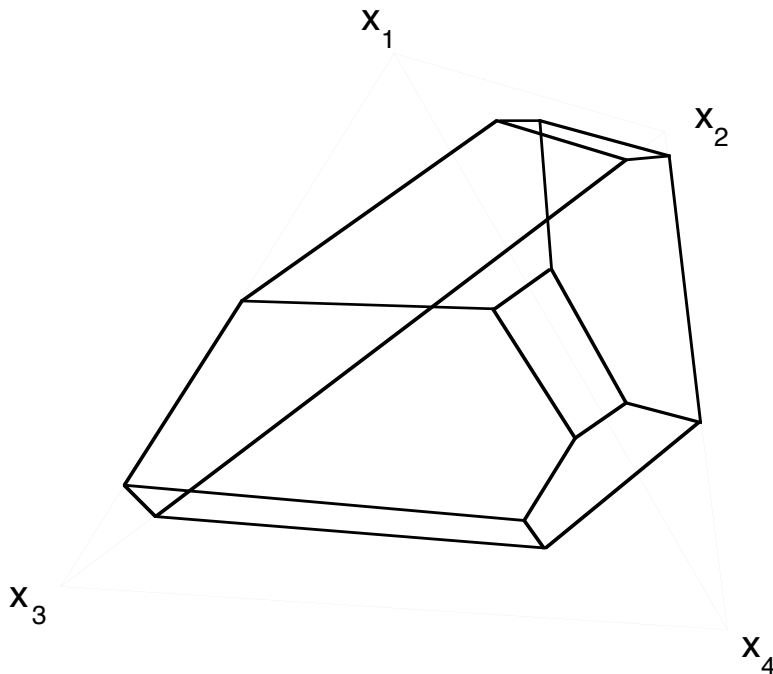

3 Double loop spaces and low dimensional coherence laws

associator



braiding

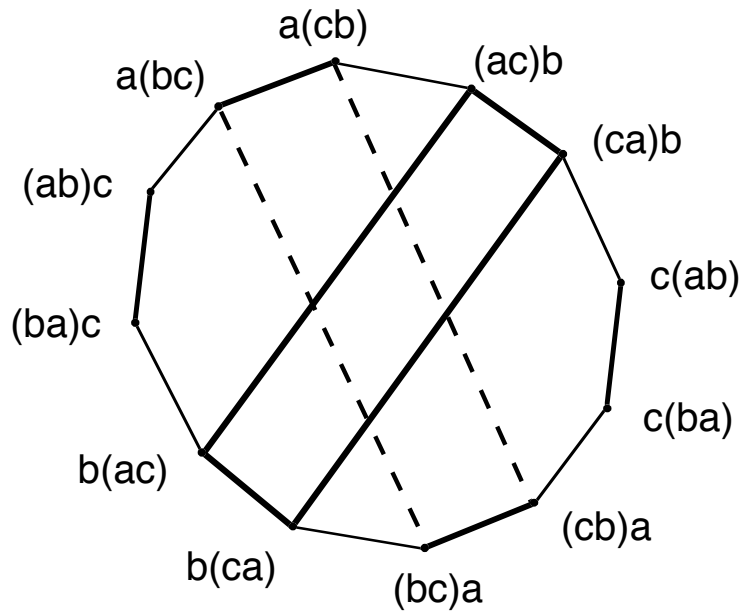
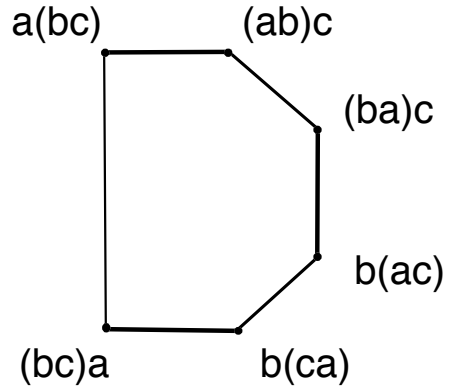
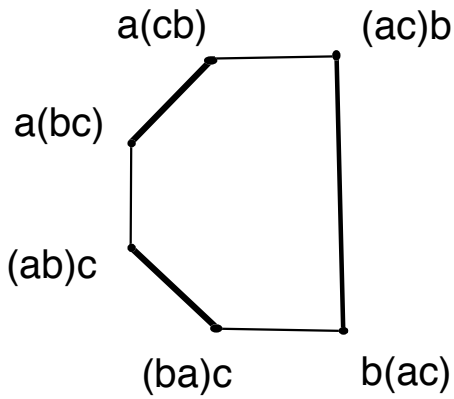

4 Operads

Notation: a finite ordinal $[n] = \{0 < 1 < \dots < n-1\}$

Definition 4.1 *An operad is a sequence of topological spaces*

$$A_{[0]}, \dots, A_{[n]}, \dots$$

together with an element $e \in A_{[1]}$ and a multiplication map

$$m_\sigma : A_{[k]} \times A_{[n_1]} \times \dots \times A_{[n_{k-1}]} \longrightarrow A_{[n]}$$

for every order preserving map

$$\sigma : [n] \rightarrow [k]$$

with the fibers $\sigma^{-1}(i) \simeq [n_i]$, satisfying associativity and unitarity conditions with respect to the composition of order preserving maps.

A picture of operadic composition

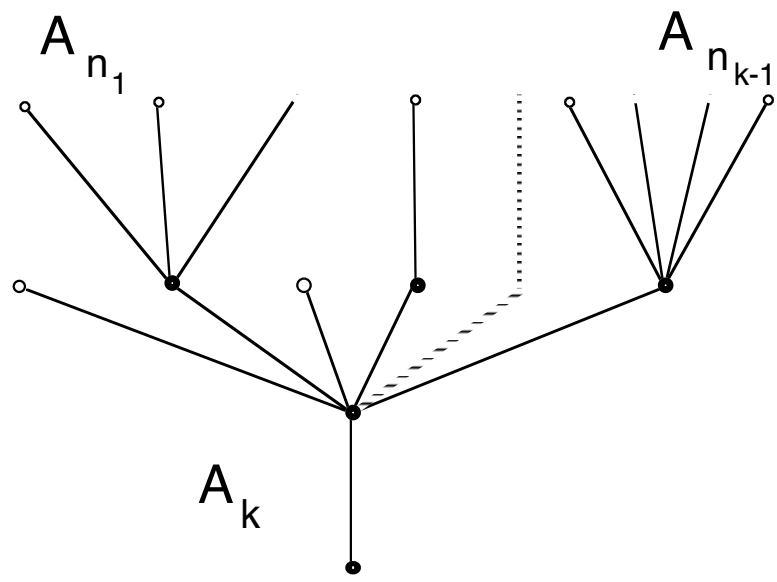
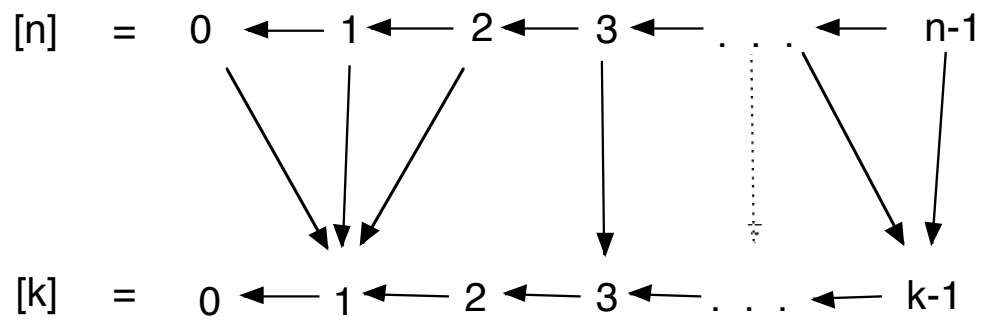

$$A_k \times A_{n_1} \times \dots \times A_{n_{k-1}} \longrightarrow A_n$$

A symmetric operad is defined analogously but we allow all maps between ordinals. Every symmetric operad is an operad. There exists an "inverse" operation sym_1 of symmetrisation of an operad.

$$sym_1(A)_n = A_n \times S_n.$$

A map of operads is a sequence of continuous maps

$$f_{[n]} : A_{[n]} \rightarrow B_{[n]}$$

which preserves the operad structures.

Example 4.1 The endomorphism operad $E(X)$ of a topological space

$$E(X)_{[n]} = Top(X^n, X).$$

The unit element is the identity map $id : X \rightarrow X$ and composition is given by substitution of functions.

Example 4.2 The sequence of associahedra $\{K_n\}_{n \geq 0}$ form an operad (A_∞ -operad).

Example 4.3 The little n -cubes operad (Boardman-Vogt-May).

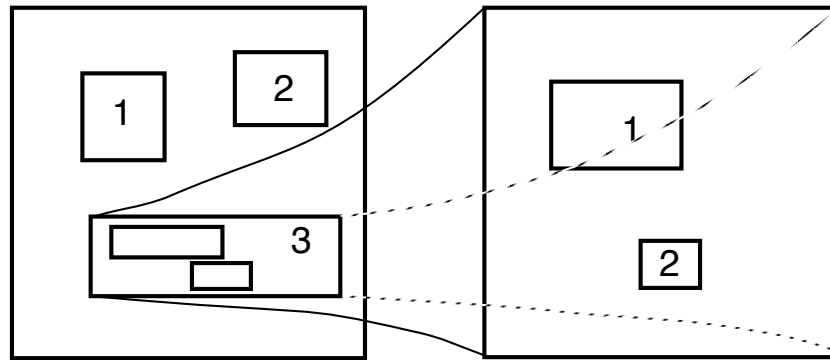

Definition 4.2 An algebra over an operad A is a topological space X together with a map of operads

$$k : A \rightarrow E(X).$$

Theorem 4.1 (Reformulation of Stasheff's theorem)

A connected based topological space is a loop space (with strict unit) if and only if it is an algebra of the operad $\mathbf{k} = \{K_n\}_{n \geq 0}$ of associahedra.

Theorem 4.2 (Boardman-Vogt, May, 1972)

A connected based topological space is an n -fold loop space (with strict unit) if and only if it is an algebra of the little n -cube operad.

5 Fulton-Macpherson compactification

The configuration space of k points in \mathbb{R}^n is

$$Conf_k(\mathbb{R}^n) = \{(x_1, \dots, x_k) \in (\mathbb{R}^n)^k \mid x_i \neq x_j \text{ if } i \neq j\}.$$

The moduli space of configurations of k -points in \mathbb{R}^n is

$$Mod_k(\mathbb{R}^n) = Conf_k(\mathbb{R}^n)/G_n$$

where G_n is the group of affine transformations of \mathbb{R}^n

$$u \in \mathbb{R}^n \longmapsto \lambda u + v, \lambda > 0, v \in \mathbb{R}^n.$$

The real compactification of moduli space of configurations (**Fulton-Macpherson, Axelrod-Singer, Kontsevich**) :

- \mathbf{fm}_k^n is the closure of $Mod_k(\mathbb{R}^n)$ in the compact space

$$\prod_{\substack{1 \leq i, j \leq k \\ i \neq j}} S^{n-1} \times \prod_{\substack{1 \leq i, j, l \leq k \\ i \neq j, j \neq l, i \neq l}} [0, \infty]$$

The inclusion is defined by the family of functions

$$u_{ij}(x_1, \dots, x_k) = \frac{x_j - x_i}{\|x_j - x_i\|}$$

$$1 \leq i, j \leq k, i \neq j$$

$$d_{i,j,l}(x_1, \dots, x_k) = \frac{\|x_i - x_j\|}{\|x_i - x_l\|}$$

$$1 \leq i, j, l \leq k, i \neq j, j \neq l, i \neq l.$$

Example 5.1

For any $n \geq 1$ the space

$$\mathbf{fm}_2^n = S^{n-1}.$$

Example 5.2 Collision of points in $Mod_{10}(\mathcal{R}^2)$

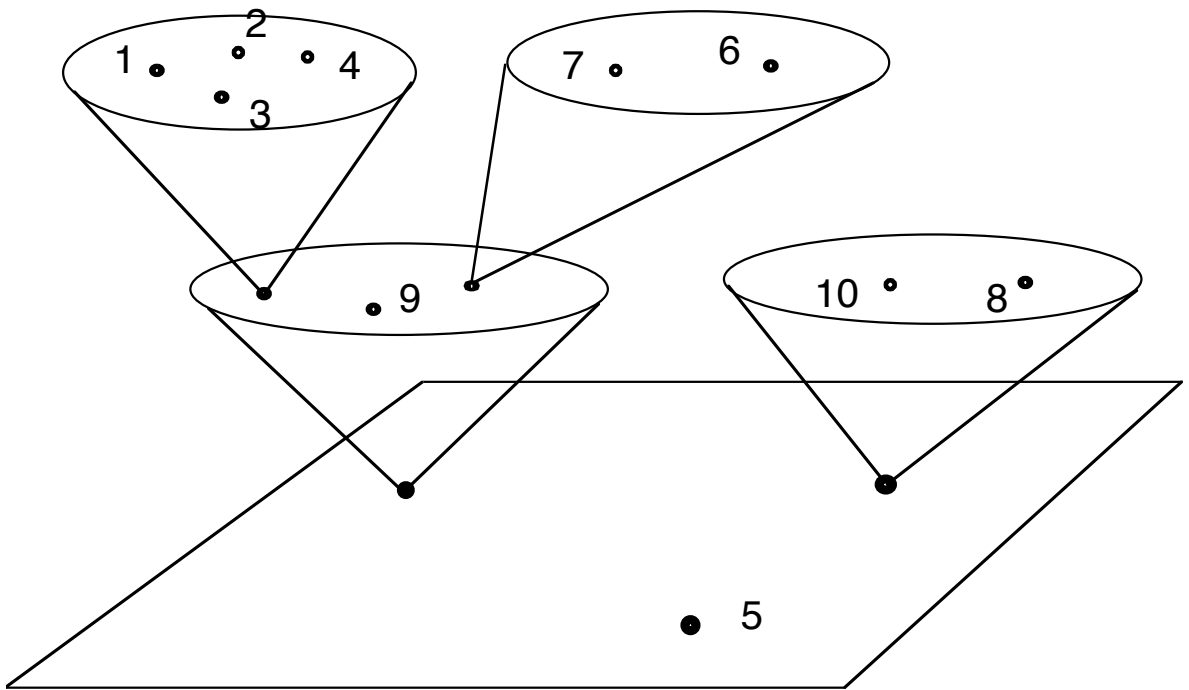

Properties of FM compactification

(**Getzler-Jones, Kontsevich**) :

- \mathbf{fm}_k^n is a manifold with corners with interior $Mod_k(\mathfrak{R}^n)$;
- The boundary strata are in bijection with nonplanar trees with labelled k leaves and a typical stratum is isomorphic to the products of low dimensional $Mod_l(\mathfrak{R}^n)$;
- The sequence $\{\mathbf{fm}_k^n\}$, $k \geq 0$ form a symmetric operad equivalent to the little n -disk operad.

Theorem 5.1 (Kontsevich, 1990) *The space \mathbf{fm}_n^1 has $n!$ connected components and each component is isomorphic to the associahedron K_n . In other words, the Fulton-Macpherson operad \mathbf{fm}^1 is the symmetrisation of Stasheff's operad*

$$\mathbf{fm}^1 = \text{sym}_1(\mathbf{k}).$$

Example 5.3 $n = 3$

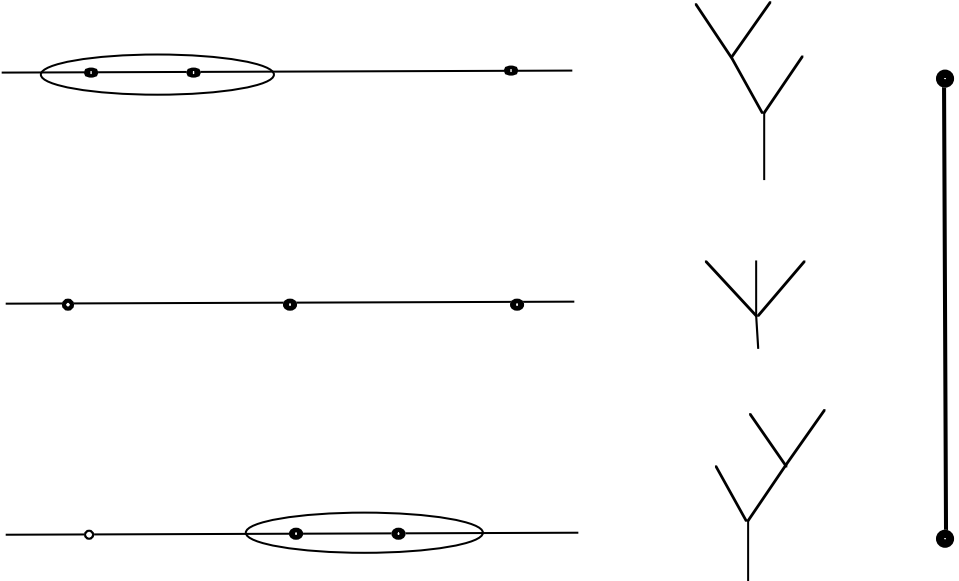

Example 5.4 $n = 4$

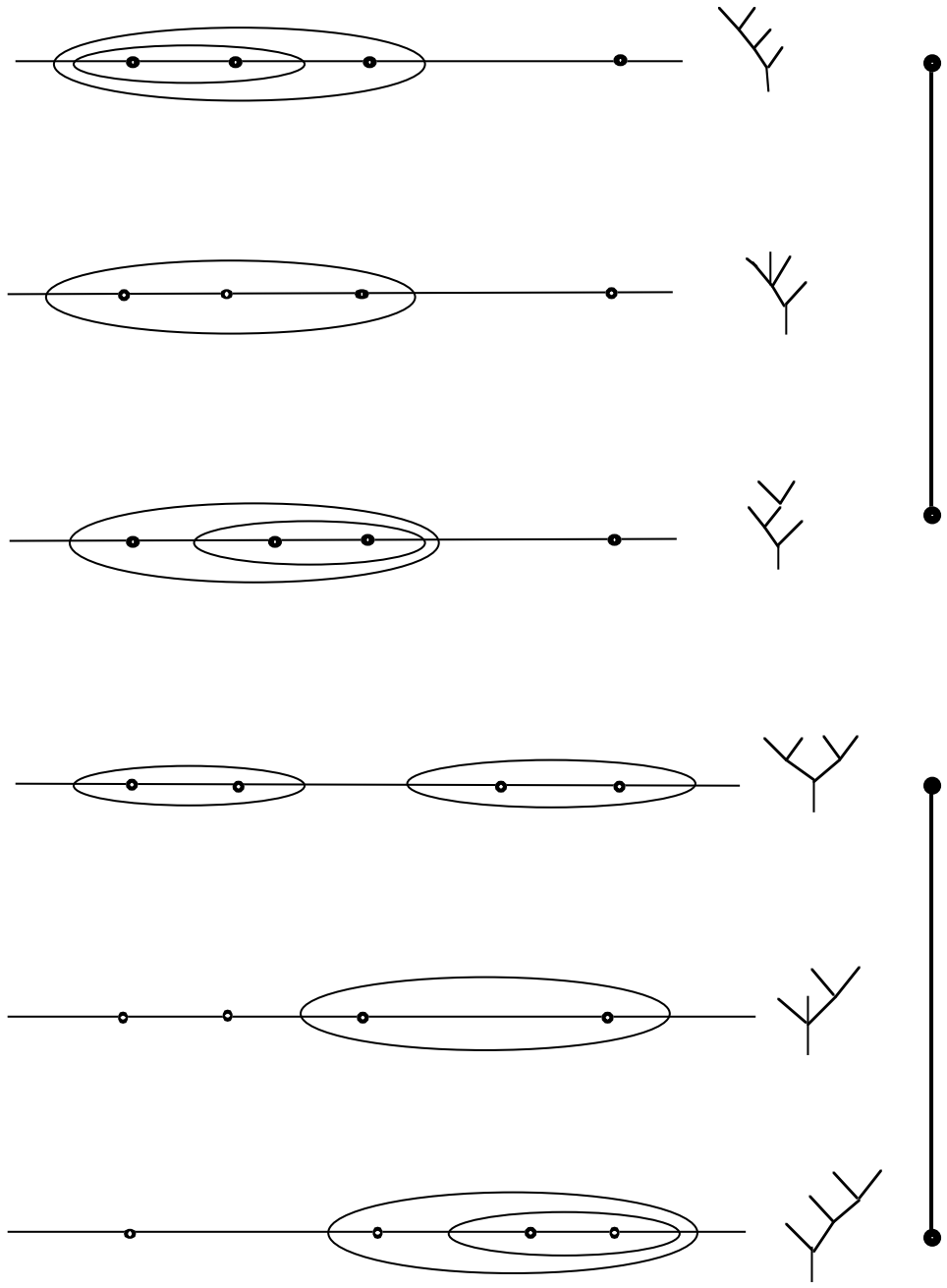

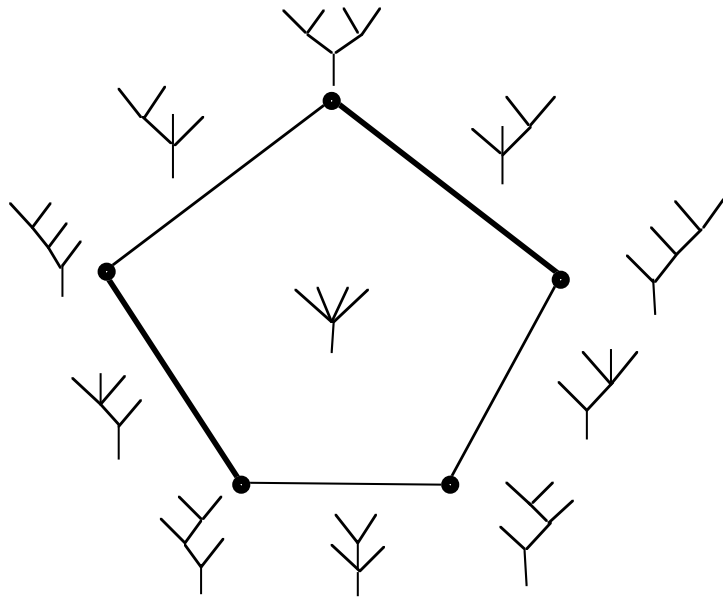

6 n-ordinals as n-dimensional natural numbers

n-category theory: **an *n*-fold loop space = a topological *n*-category with one object, one 1-arrow, one 2-arrow etc. one (*n* − 1)-arrow.**

The structure should be describable by higher categorical tools.

Definition 6.1 *Let X be a finite set equipped with n binary relations $<_0, \dots, <_{n-1}$. X is called an n -ordinal if these relations satisfy the following properties*

- $<_p$ is nonreflexive and antisymmetric;
- for every pair $a, b \in X$, there exists exactly one p such that

$$a <_p b \text{ or } b <_p a;$$

- if $a <_p b$ and $b <_q c$ then $a <_{\min(p,q)} c$.

Every n -ordinal can be represented as a planar tree with n -levels or as n -dimensional graph

1-ordinals

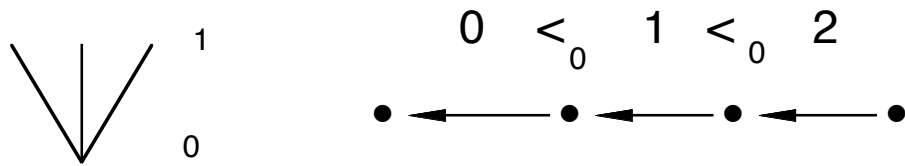

2-ordinals

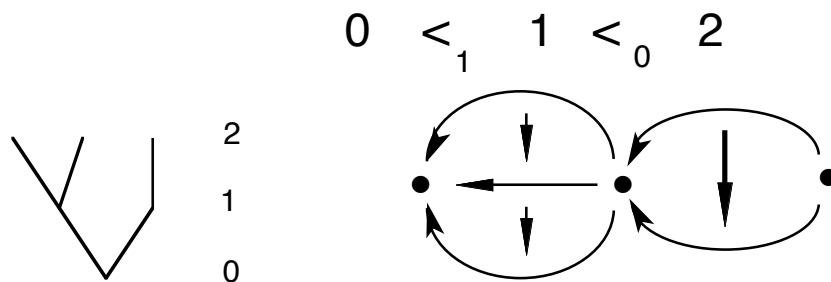
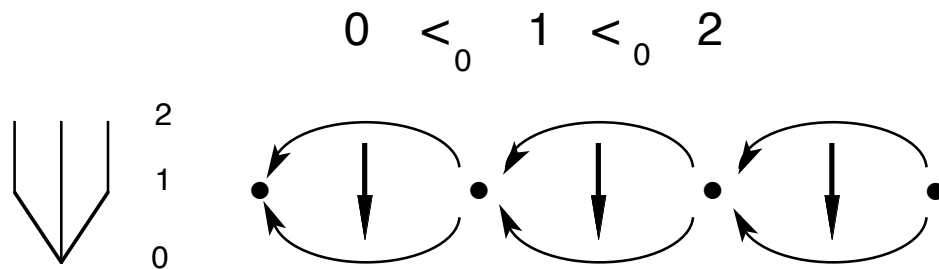
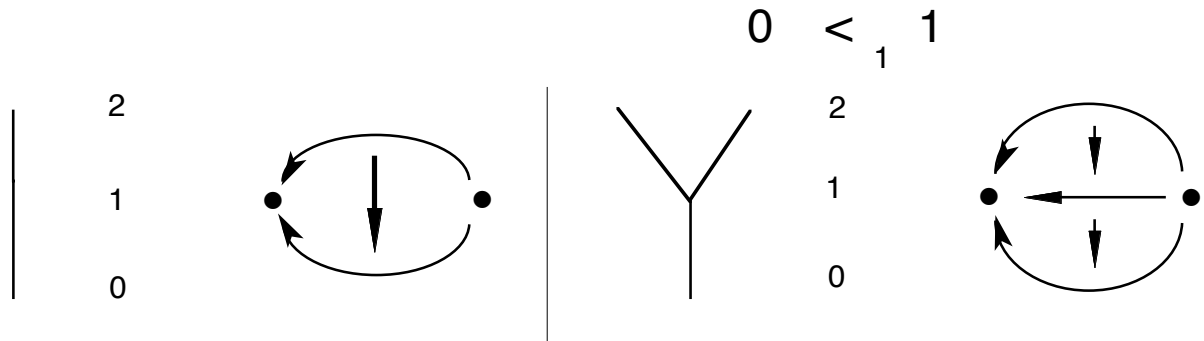

Definition 6.2 *A map of n -ordinals*

$$\sigma : X \rightarrow Y$$

is a map $\sigma : X \rightarrow Y$ of underlying sets such that

$$i <_p j \text{ in } X$$

implies that

- $\sigma(i) <_r \sigma(j)$ for some $r \geq p$ or
- $\sigma(i) = \sigma(j)$ or
- $\sigma(j) <_r \sigma(i)$ for $r > p$.

For every $i \in Y$ the preimage $\sigma^{-1}(i)$ (**the fiber of σ over i**) has a natural structure of an n -ordinal.

7 n-operads

Definition 7.1 *An n -operad is a family of topological spaces*

$$A_T, T \in \text{Ord}_n,$$

together with an element $e \in A_1$, where 1 is the terminal n -ordinal and a multiplication map

$$m_\sigma : A_S \times A_{T_1} \times \dots \times A_{T_k} \longrightarrow A_T$$

for every order preserving map of n -ordinals

$$\sigma : T \rightarrow S$$

with the fibers $\sigma^{-1}(i) \simeq T_i$, $i \in S$, satisfying associativity and unitarity conditions with respect to the composition of order preserving maps.

Example 7.1 An endomorphism operad of a topological space X :

$$E(X)_T = \text{Top}(X^T, X), \quad T \in \text{Ord}_n,$$

where $X^T = X^{|T|}$ and $|T|$ is the underlying set of T (the number of leaves of the tree T).

Example 7.2 A 1-operad is the same as a classical (nonsymmetric) operad.

Definition 7.2 *An algebra of an n -operad A is a pointed topological space X equipped with a map of n -operads $A \rightarrow E(X)$.*

As in the case of ordinary operads an A -algebra structure on X amounts to a family of continuous maps

$$m_T : A_T \times X^T \rightarrow X$$

satisfying some compatibility conditions with respect to composition of functions and operad composition in A .

8 Stratification, compactification and higher dimensional coherence laws

We have seen before that with every 1-ordinal $[m]$ one can associate an open $(m - 2)$ -dimensional cell

$$FN_{[m]} = \{(x_1 < x_2 < \dots < x_m)\} \subset \text{Mod}_m(\mathfrak{R}^1)$$

and the closure of it in \mathbf{fm}_m^1 is exactly the associahedron K_m .

We have a similar association for n -ordinals.

Let $\overset{o}{S}_+^{n-p-1}$ denote the open $(n - p - 1)$ -hemisphere in \mathfrak{R}^n , $0 \leq p \leq n - 1$:

$$\overset{o}{S}_+^{n-p-1} = \left\{ x \in \mathfrak{R}^n \left| \begin{array}{l} x_1^2 + \dots + x_n^2 = 1 \\ x_{p+1} > 0 \text{ and } x_i = 0 \text{ if } 1 \leq i \leq p \end{array} \right. \right\}$$

Similarly,

$$\overset{o}{S}_-^{n-p-1} = \left\{ x \in \mathfrak{R}^n \left| \begin{array}{l} x_1^2 + \dots + x_n^2 = 1 \\ x_{p+1} < 0 \text{ and } x_i = 0 \text{ if } 1 \leq i \leq p \end{array} \right. \right\} .$$

The Fox-Neuwirth cell corresponding to an n -ordinal T is a subspace of $Mod_{|T|}(\mathfrak{R}^n)$

$$FN_T = \left\{ x \in Mod_{|T|}(\mathfrak{R}^n) \left| \begin{array}{l} u_{ij}(x) \in \overset{o}{S}_+^{n-p-1} \quad \text{if } i <_p j \text{ in } T \\ u_{ij}(x) \in \overset{o}{S}_-^{n-p-1} \quad \text{if } j <_p i \text{ in } T \end{array} \right. \right\} .$$

It is a contractible open manifold of dimension

$$E(T) - n - 1$$

where $E(T)$ is the number of edges in the tree T .

Example 8.1

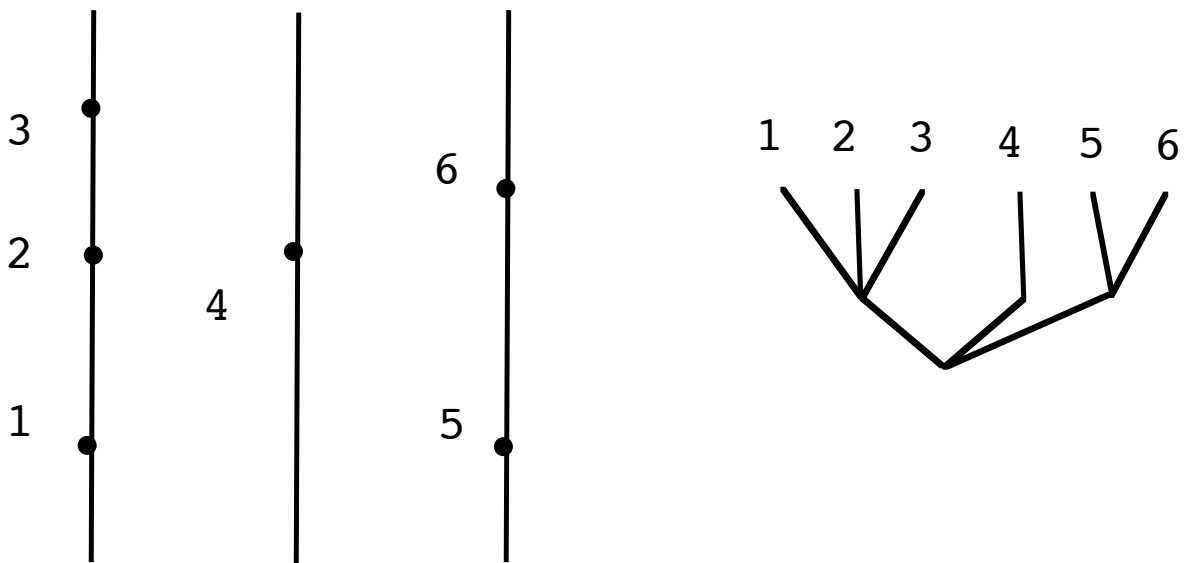

The Getzler-Jones space

$$\mathbf{GJ}_T^n = \left\{ x \in \mathbf{fm}_{|T|}^n \mid \begin{array}{l} u_{ij}(x) \in S_+^{n-p-1} \quad \text{if } i <_p j \text{ in } T \\ u_{ij}(x) \in S_-^{n-p-1} \quad \text{if } j <_p i \text{ in } T \end{array} \right\} .$$

where S_+^{n-p-1} and S_-^{n-p-1} are closures of $\overset{o}{S}_+^{n-p-1}$ and $\overset{o}{S}_-^{n-p-1}$ respectively.

Theorem 8.1 *The family of spaces*

$$\{\mathbf{GJ}_T^n\}, \quad T \in \text{Ord}_n,$$

form a contractible n -operad.

Example 8.2 \mathbf{GJ}^1 is isomorphic to the Stasheff's operad \mathbf{k} of associahedra.

The following theorem generalises Kontsevich's observation for arbitrary n and gives a precise recipe how to construct \mathbf{fm}^n by gluing Getzler-Jones spaces.

Theorem 8.2

$$\mathbf{fm}^n = \mathit{sym}_n(\mathbf{GJ}^n),$$

where for an n -operad A

$$\mathit{sym}_n(A)_k = \mathit{colim}_{T \in J_k^n} A_T,$$

J_k^n is the Milgram poset.

For an n -ordinal T , let K_T be the closure of the Fox-Neuwirth cell FN_T in the Getzler-Jones space \mathbf{GJ}_T^n .

Theorem 8.3

- K_T is a manifold with corners combinatorially equivalent to the ball of dimension $E(T) - n - 1$;
- The faces of codimension one of K_T are given by products and collapsing of low-dimensional K_S .

The following analogue of Stasheff's theorem holds:

Theorem 8.4 *A connected base space Y is an n -fold loop space (with strict units) if and only if there exists a sequence of operations*

$$\mu_T : K_T \times Y^T \rightarrow Y$$

where $\mu_T/\partial K_T$ is constructed from low dimensional K_S and such that the base point of Y is a strict unit for μ_T .

The last condition is equivalent to the existence of a \mathbf{GJ}^n -algebra structure on Y , which in its turn is equivalent to the existence of a \mathbf{fm}^n -algebra structure on Y .

Here are the examples of low dimensional K_T .

n = 2

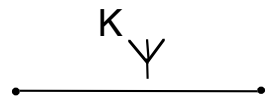

Poincaré (1895)

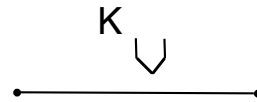

Alexandroff, Hopf (1930)

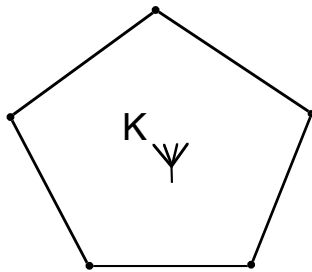

MacLane, Stasheff (1963)

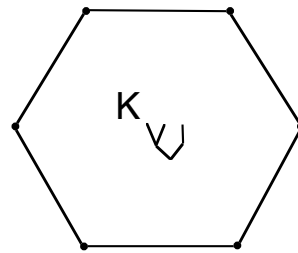

Drinfeld, Joyal, Street (1985)

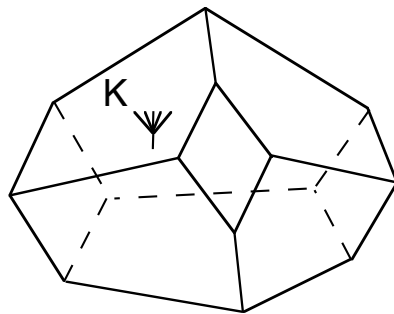

Stasheff (1963)

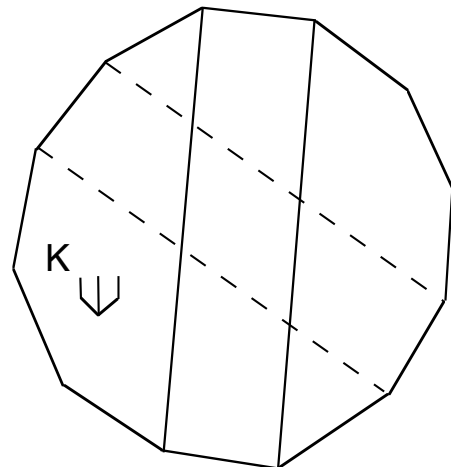

Breen (1990)

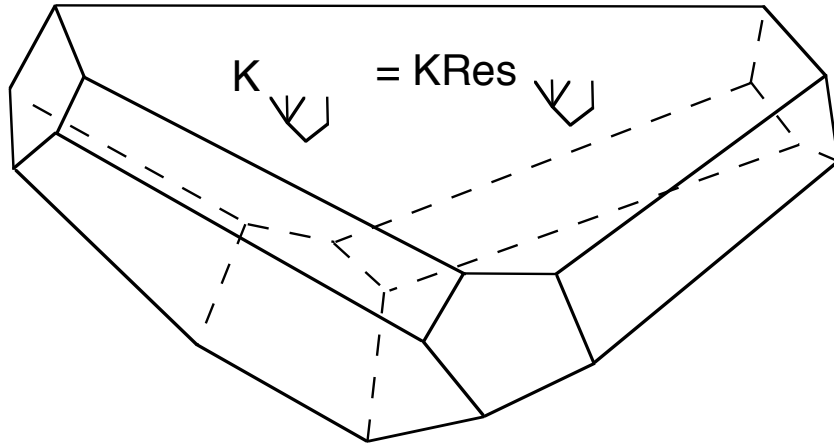

generalised resultoassociahedra

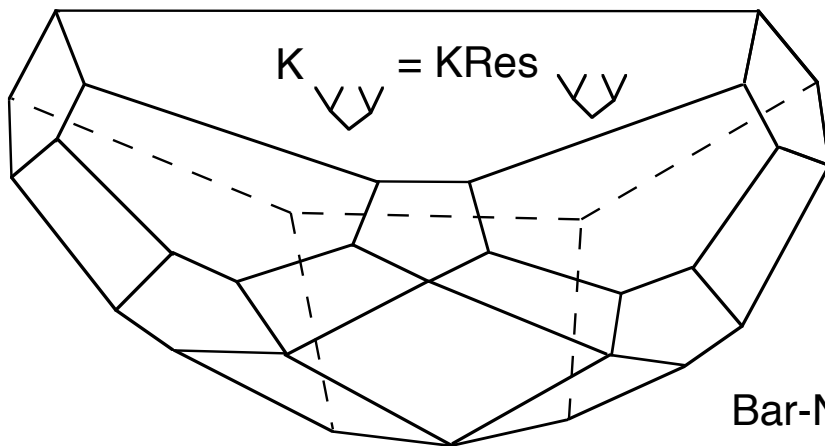

Bar-Natan (1993)

n = 3

n = 4

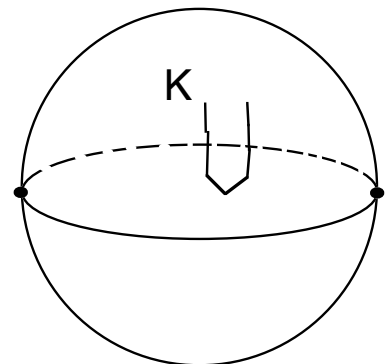
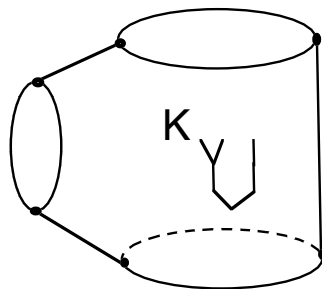
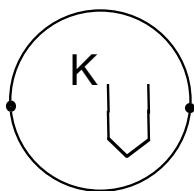

Warning !

[**Tamarkin's counterexample 1998**]

The polytope K_T coincides with \mathbf{GJ}_T until dimension **5**. The first difference appears in the dimension **6** for a space of operation of **6** variables ! [Configurations of **6** points on the plane.]

The arity of these operations is given by the following 2-ordinal

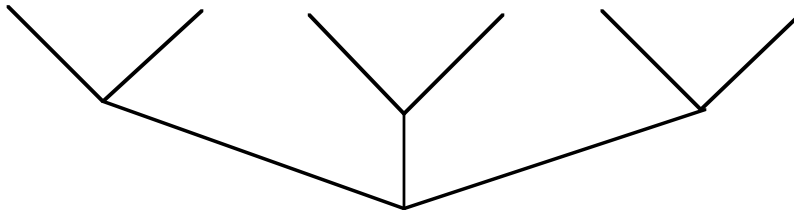

So, in contrast with the classical 1-dimensional case, **the polytopes K_T do not form an n -operad for $n \geq 2$.**

\mathbf{GJ}^n is an n -operad but \mathbf{GJ}_T^n in general is just *a semialgebraic set*.

9 n-operadic compactification

To overcome the difficulties created by Tamarkin's counterexample we introduce a bigger compactification of configuration space which gives an n -operad \mathbf{B}^n which is a true n -dimensional analogue of Stasheff's operad. The space \mathbf{B}_T can be obtained by a further blow-up procedure from K_T . It is a closure of FN_T inside the following product

$$\begin{aligned}
 & \prod_{\substack{1 \leq i, j \leq |T| \\ i \neq j}} S^{n-1} \times \prod_{\substack{1 \leq i, j, l \leq |T| \\ i \neq j, j \neq l, i \neq l}} [0, \infty] \times \\
 & \prod_{\substack{1 \leq i, j \leq |\partial T| \\ i \neq j}} S^{n-2} \times \prod_{\substack{1 \leq i, j, l \leq |\partial T| \\ i \neq j, j \neq l, i \neq l}} [0, \infty] \times \\
 & \prod_{\substack{1 \leq i, j \leq |\partial^2 T| \\ i \neq j}} S^{n-3} \times \prod_{\substack{1 \leq i, j, l \leq |\partial^2 T| \\ i \neq j, j \neq l, i \neq l}} [0, \infty] \times \\
 & \dots\dots\dots \\
 & \prod_{\substack{1 \leq i, j \leq |\partial^{n-1} T| \\ i \neq j}} S^0 \times \prod_{\substack{1 \leq i, j, l \leq |\partial^{n-1} T| \\ i \neq j, j \neq l, i \neq l}} [0, \infty].
 \end{aligned}$$

The notation ∂T here means an $(n-1)$ -ordinal whose underlying set is the set of equivalence classes of elements of T with respect to the equivalence relation generated by the relation $<_{n-1}$ on T .



The embedding is given by functions

$$u_{ij}, d_{ijl}, \dots, u_{ij}(p^k), d_{ijl}(p^k), \dots, \dots$$

and p^k is the natural projection from

$$FN_T \rightarrow FN_{\partial^k T}.$$

We have the induced projections

$$\mathbf{B}_T \rightarrow \mathbf{B}_{\partial T} \rightarrow \mathbf{B}_{\partial^2 T} \rightarrow \dots \rightarrow \mathbf{B}_{\partial^n T} = \{pt\}.$$

One can define a more general notion of n -operad where the projection above is a part of the structure of an operad.

Theorem 9.1

- \mathbf{B}_T form an n -operad
- \mathbf{B}_T is a manifold with corners combinatorially equivalent to the ball of dimension $E(T) - n - 1$;
- The faces of codimension one of \mathbf{B}_T are given by products of generalised resultoassociahedra;
- K_T can be obtained as a quotient of \mathbf{B}_T by collapsing some faces in \mathbf{B}_T .

The following is another n -dimensional analogue of Stasheff's theorem

Theorem 9.2 *A space Y is an \mathbf{B}^n -algebra if and only if X is an \mathbf{GJ}^n -algebra, if and only if X is an \mathbf{fm}^n -algebra.*

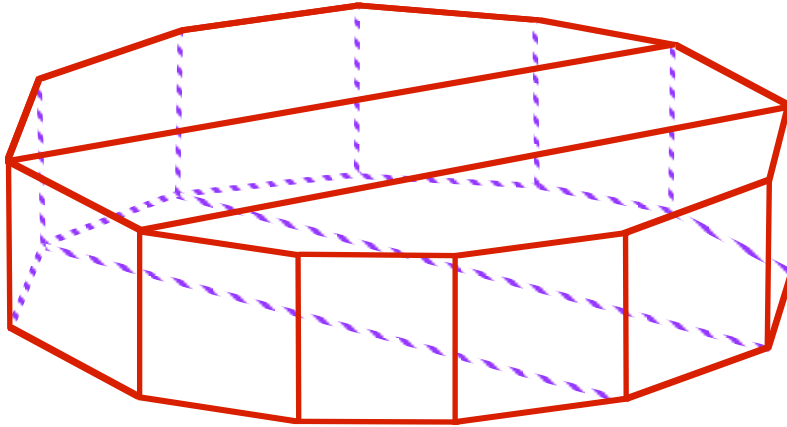

B \Downarrow

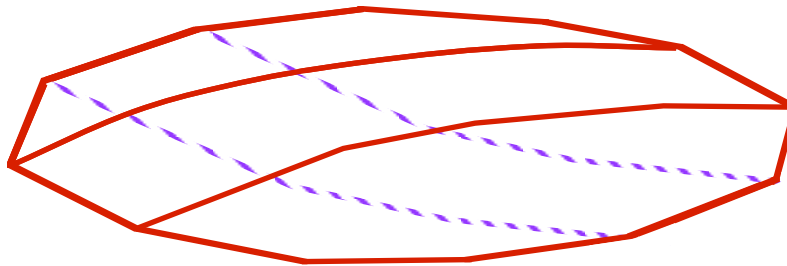

K \Downarrow

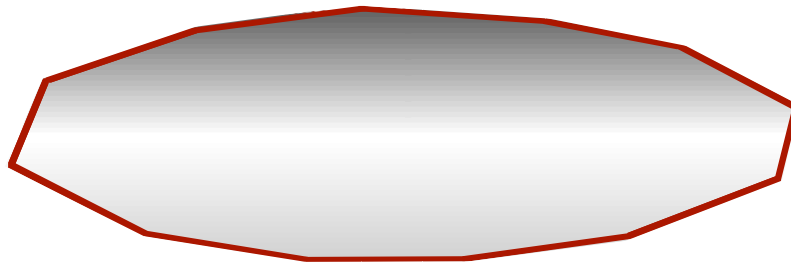













































Permutoassociahedron

$KP_3 = KRes$ \Downarrow

10 The Table of coherence laws

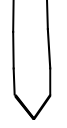
Getzler-Jones, Baez-Dolan, Batanin

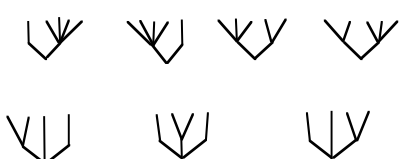
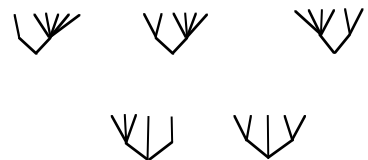
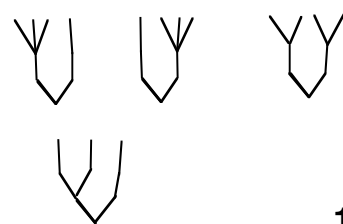
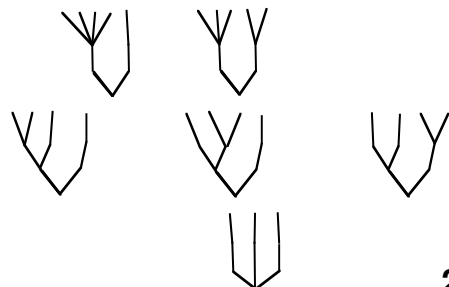
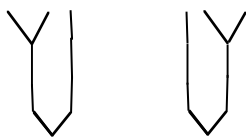
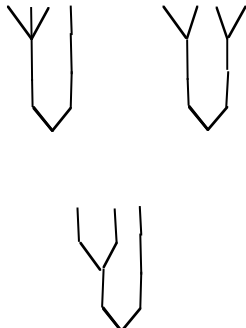
$\begin{matrix} \text{dim} \\ \text{h} \end{matrix} \backslash$	0	1	2	3
$\begin{matrix} 1 \\ \mathbf{F}_{n,1} \end{matrix}$	 1	 1	 1	 1
$\begin{matrix} 2 \\ \mathbf{F}_{n,2} \end{matrix}$	 stable 1	  2	   3	     5
$\begin{matrix} 3 \\ \mathbf{F}_{n,3} \end{matrix}$	 1	  stable 2	    4	       7
$\begin{matrix} 4 \\ \mathbf{F}_{n,4} \end{matrix}$	 1	  2	    stable 4	        8

dim h	4	5
2		
$F_{n,2}$	8	13
3		
$F_{n,3}$	13	24
4		
$F_{n,4}$	15	29
5		
	16	31
6	stable	
	16	32

References

- [1] Baez J., Dolan J., Higher-dimensional algebra and topological quantum field theory, *Journal Math. Phys.* **36** (1995), 6073-6105.
- [2] Baez J., Dolan J., Categorification, *Contemp. Math.* AMS, **230** (1998), 1-36.
- [3] Batanin M.A., Monoidal globular categories as a natural environment for the theory of weak n -categories, *Adv. Math.* **136** (1998), 39-103.
- [4] Batanin M.A., The Eckman-Hilton argument and higher operads, preprint, math.CT/0207281 .
- [5] Batanin M.A., Symmetrisation of n -operads and compactification of configuration spaces, math.CT/0606067, to appear in *Adv. Math.*,
- [6] Batanin M.A., Street R., The universal property of the multitude of trees, *Journal of Pure and Appl. Algebra* **154** (2000), 3-13.
- [7] Bar-Natan D., Non-associative tangles, *1AMS/IP Stud. Adv. Math.*, **2.1** (1997) , 139–183.
- [8] Berger C., Combinatorial models for real configuration spaces and E_n -operads, *Contemp. Math.* **202** (1997), 37-52.
- [9] Fox R., Neuwirth L., The braid groups, *Math. Scand.*, **10** (1962) 119-126.

- [10] Gelfand I.M., Kapranov M.M., Zelevinsky A.V., Newton polytopes of classical determinant and resultant, *Adv. Math.*, 84 (1990), 255-271,
- [11] Getzler E., Jones J.D.S., Operads homotopy algebra, and iterated integrals for double loop spaces, *Warwick Preprints*, 1994.
- [12] Ginzburg V., Kapranov M., Koszul duality for operads, *Duke Math. J.*, 76 (1994), 203-272.
- [13] Joyal A., Street R., Braided tensor categories, *Adv. Math.*, 102 (1993), 20-78.
- [14] Joyal A., Disks, duality and Θ -categories, preprint, 1997.
- [15] Kapranov M., The Permutoassociahedron, MacLane's coherence theorem and asymptotic zones for the KZ equation, *JPAA*, 85(1993), 119-142.
- [16] Kapranov M., Voevodsky V., 2-Categories and Zamolodchikov tetrahedra equations, in *Proc. Symp. Pure Math.*, 56 p.2 (1994), AMS, Providence, pp. 177-260.
- [17] Kontsevich M., Operads and motives in deformation quantization, *Lett. Math. Phys.* 48 (1999), no. 1, 35–72.
- [18] Kontsevich M., Soibelman Y., Deformation of algebras over operads and Deligne's conjecture, *Conférence Moshé Flato 1(Dijon)* (1999), 255–307.
- [19] MacLane S., Categories for the Working Mathematician, *Second edition. Graduate Texts in Mathematics*, 5 Springer-Verlag, New York, 1998.

- [20] Markl M., A compactification of the real configuration space as an operadic completion, *J. Algebra* 215 (1999), no. 1, 185–204.
- [21] Markl M., Shnider S., Stasheff J., Operads in Algebra, Topology and Physics, *Math. Surveys and Monographs*, v.96, AMS, 2002.
- [22] May P., The Geometry of Iterated Loop Spaces, *Lecture Notes in Math.*, 271, Springer Verlag, Berlin, (1972).
- [23] Sinha D., Manifold-theoretic compactifications of configuration spaces, *Selecta Math.* 10 (2004), no. 3, 391–428.
- [24] Street R., The petit topos of globular sets, *Journal of Pure and Appl. Algebra*, 154 (2000), 299-315.
- [25] Stasheff J.D., Homotopy associativity of H-spaces, I, *Trans. Amer. Math. Soc.*, 108, (1963), 275-292.
- [26] Stasheff J.D., Homotopy associativity of H-spaces, II, *Trans. Amer. Math. Soc.*, 108, (1963), 293-312.
- [27] Tamarkin D.E., What do DG -categories form? , to appear in *Compositio Math.*, available at math.CT/0606553 .
- [28] Voronov A., Homotopy Gerstenhaber algebras, *Conference Mosh Flato 1999, II (Dijon)*, 307–331, *Math. Phys. Stud.*, 22, Kluwer Acad. Publ., Dordrecht, (2000).
- [29] Voronov A., The Swiss-cheese operad, *Contemp. Math.*, 239 (1998) 365–373.