

SHAPELY MONADS AND ANALYTIC FUNCTORS

RICHARD GARNER AND TOM HIRSCHOWITZ

ABSTRACT. In this paper, we give precise mathematical form to the idea of a structure whose data and axioms are faithfully represented by a graphical calculus; some prominent examples are operads, polycategories, properads, and PROPs. Building on the established presentation of such structures as algebras for monads on presheaf categories, we describe a characteristic property of the associated monads—the *shapeliness* of the title—which says that “any two operations of the same shape agree”.

An important part of this work is the study of *analytic* functors between presheaf categories, which are a common generalisation of Joyal’s analytic endofunctors on sets and of the parametric right adjoint functors on presheaf categories introduced by Diers and studied by Carboni–Johnstone, Leinster and Weber. Our shapely monads will be found among the analytic endofunctors, and may be characterised as the submonads of a *universal* analytic monad with “exactly one operation of each shape”.

In fact, shapeliness also gives a way to *define* the data and axioms of a structure directly from its graphical calculus, by generating a free shapely monad on the basic operations of the calculus. In this paper we do this for some of the examples listed above; in future work, we intend to use this to obtain canonical notions of denotational model for graphical calculi such as Milner’s bigraphs, Lafont’s interaction nets, or Girard’s multiplicative proof nets.

1. INTRODUCTION

In mathematics and computer science, we often encounter structures which are faithfully encoded by a graphical calculus of the following sort. The basic data of the structure are depicted as certain diagrams; the basic operations of the structure act by glueing together these diagrams along certain parts of their boundaries; and the axioms of the structure are just those necessary to ensure that “every two ways of glueing a compound diagram together agree”.

Commonly, such calculi depict structures wherein “functions”, “arrows” or “processes” are wired together along input or output “ports”. For instance, we have *multicategories* [23], whose arrows have many inputs but only one output; *polycategories* [33], whose arrows have multiple inputs and outputs, with composition subject to a linear wiring discipline; and *coloured properads* [35] and PROPs [27], which are like polycategories but allow for non-linear wirings.

Mathematical structures such as these are important in algebraic topology and homological algebra—encoding, for example, operations arising on infinite loop

Hirschowitz acknowledges the support of the French ANR projet blanc Récré ANR-11-BS02-0010; Garner acknowledges the support of the Australian Research Council Discovery Projects DP110102360 and DP130101969. This research was partially undertaken during a visit by Hirschowitz to Sydney funded by Macquarie University.

spaces [29] or on Hochschild cochains [30]—but also in logic and computer science. For example, polycategories encode the underlying semantics of a linear sequent calculus [24], while PROPs have recently been used as an algebraic foundation for notions of computational network such as signal flow graphs [3] and Bayesian networks [9]. Other kinds of graphical structures arising in computer science include *proof nets* [11, §2], *interaction nets* [22] and *bigraphs* [14].

There is an established approach to describing structures of the above kind using monads on presheaf categories. The presheaf category captures the essential topology of the underlying graphical calculus, while the monad encodes both the wiring operations of the structure and the axioms that they obey; the algebras for the monad are the instances of the structure. One aspect which this approach does not account for is that the axioms should be determined by the requirement that “every two ways of wiring a compound diagram together agree”. The first main contribution of this paper is to rectify this: we explain the observed form of the axioms as a property of the associated monad—which we term *shapeliness*—stating that “every two operations of the same shape coincide”.

In fact, shapeliness gives not just a way of *characterising* the monads encoding graphical structures, but also a systematic way of *generating* them. For a given graphical calculus, it is typically easy to find a presheaf category encoding the basic diagram-shapes of the calculus, and an endofunctor thereon encoding the basic wiring operations; we then obtain the desired monad as the *free shapely monad* on the given endofunctor. The algebras for this monad can be seen as denotational models of the graphical calculus in question; and though we do not do this here, one can envisage this being used to attach workable denotational semantics to, for example, interaction nets; the syntactic part of bigraphs; or MLL proof nets without units.

Formalising the notion of shapely monad turns out to be a delicate task. In the end, we will define a monad on $\mathcal{P}\mathcal{C} = [\mathcal{C}^{\text{op}}, \mathbf{Set}]$ to be *shapely* just when it is a submonad of a *universal* shapely monad \mathbf{U} with “exactly one operation of each shape”. We will find \mathbf{U} by seeking a terminal object in a suitable monoidal category of *endofunctors* of $\mathcal{P}\mathcal{C}$; once found, terminality will automatically endow this object with a monad structure, so giving the desired \mathbf{U} .

This leaves the problem of choosing a suitable monoidal category of endofunctors. An obvious but wrong choice would be the whole functor category $[\mathcal{P}\mathcal{C}, \mathcal{P}\mathcal{C}]$: with this choice, \mathbf{U} would be the monad constant at 1, and a general monad would be shapely just when it took values in subobjects of 1. This is manifestly not what we want; the problem is that terminality in the full functor category encodes the property of having “exactly one operation of each shape” for what are overly crude notions of “operation” and “operation shape”.

Refining these notions, as we shall do, means looking for a terminal object in some smaller category of endofunctors of $\mathcal{P}\mathcal{C}$. Choosing this category turns out to be an interesting design problem: some natural candidates have a terminal object, but are not closed under composition, while others are closed under composition, but fail to have a terminal object. Our eventual solution will triangulate between these failures, but we make no claims to its definitiveness; in

fact, we consider the value of our work to lie as much in the exploration of the problem's design space as in the particular solution we adopt.

The technical foundation of our approach will be a theory of *analytic functors* between presheaf categories, and the second main contribution of this paper is to develop such a theory. Analytic endofunctors of **Set** were introduced by Joyal in [16] as a categorical foundation for enumerative combinatorics; their importance for computer science has been recognised in work such as [1, 8, 12]. An endofunctor F of **Set** is *analytic* in Joyal's sense when it can be written in the form:

$$FX = \sum_{i \in I} X^{\alpha_i}_{/G_i}$$

for an I -indexed family of natural numbers α_i and subgroups $G_i \leq \mathfrak{S}_{\alpha_i}$; the quotients are by the permutation actions of G_i on the factors of X^{α_i} .

Various authors have considered various ways of extending Joyal's notion to arbitrary presheaf categories, as, for example, in [1, 8]. However, it turns out that these prior notions are not appropriate to our needs, since the notions of analyticity they describe are not general enough to capture the functors and monads of interest (see Remark 4.5 below). Instead, guided by our applications, we choose to call a functor $F: \mathcal{P}\mathcal{D} \rightarrow \mathcal{P}\mathcal{C}$ *analytic* if it takes the form:

$$(1.1) \quad FX(c) = \sum_{i \in I_c} \mathcal{P}\mathcal{D}(\alpha_i, X)_{/G_i}$$

for some family of presheaves $\alpha_i \in \mathcal{P}\mathcal{D}$ and subgroups $G_i \leq \text{Aut}(\alpha_i)$ of the automorphism group of each α_i . Just as in the case studied in [16], these generalised analytic functors have a strongly combinatorial flavour; moreover, all of the monads derived from graphical calculi that we will consider turn out to be analytic in this sense.

It is therefore reasonable that we should look for a universal shapely monad among analytic endofunctors of a presheaf category. While we do not succeed in doing this in full generality, our attempts to do so lead us to develop various results of independent interest, including the following:

- (i) We give a combinatorial representation of the category of finitary analytic functors and transformations $\mathcal{P}\mathcal{C} \rightarrow \mathcal{P}\mathcal{D}$ (Proposition 4.17) and show that this category always has a terminal object (Proposition 4.21).
- (ii) We show that analytic functors between presheaf categories need *not* be closed under composition (Proposition 4.24); this is by contrast to analytic endofunctors of **Set**, which *are* composition-closed.
- (iii) We introduce a condition on analytic functors which we call *cellularity*, that is sufficient to ensure that they do compose (Proposition 5.16).
- (iv) We see that, unfortunately, the introduction of cellularity also destroys the terminal object among finitary analytic endofunctors (Proposition 5.21).

This last, negative, result delineates the boundary of our knowledge in the general case; but a small adaptation allows us to obtain positive results in the specific cases necessary to talk about PROPS, properads and polycategories. As we recall, each of these notions may be encoded by a monad on a suitable presheaf category of *polygraphs* (Definitions 2.5 and 2.11). What we further show is that:

- For endofunctors of the category of polygraphs, the notion of cellularity can be augmented with simple *ad hoc* conditions to obtain a class of analytic functors which is composition-closed and admits a terminal object (Propositions 6.2 and 6.4).
- In this context, therefore, there exists a universal shapely monad, and moreover, we may describe concretely the free shapely monad on any shapely endofunctor (Proposition 6.13).
- The monads for polycategories, properads and PROPs are the free shapely monads on the endofunctors encoding their basic wiring operations (Theorems 6.15 and 6.16).

We conclude this introduction with a brief overview of the rest of the paper. We start in Section 2 by developing some motivating examples of graphical calculi and the algebraic structures they describe. These graphical calculi include that for symmetric monoidal categories introduced in [17] (but see also [31]); the associated algebraic structures include the *polycategories* of [32], the (coloured) *properads* of [35], and the PROPs of [27]. We then explain how these algebraic structures can be described as the algebras for a monad on a presheaf category.

In Section 3, we begin our pursuit of the notion of universal shapely monad. We do not immediately consider the analytic functors discussed above, but rather the narrower class of *familially representable* or *familial* functors, introduced by Diers [6] and studied by Johnstone, Leinster and Weber [5, 37, 26]; these are precisely the analytic functors whose expression (1.1) involves only *trivial* groups G_i . We recall basic aspects of the theory of familial functors, including closure under composition, but show that there is typically no terminal object among familial endofunctors, and hence no universal shapely monad among them.

In Section 4, we attempt to fix up the lack of a terminal object among familial endofunctors by passing to the more general analytic functors. As is visible from (i) and (ii) above, we succeed in doing this, but only at the cost of breaking the composability of familial endofunctors. Section 5 attempts to fix this new problem by introducing the more restricted class of *cellular* analytic functors; as in (iii) and (iv) above, this does indeed resolve the problem of composability but at the same time reintroduces the problem of the existence of a terminal object.

At this point, in Section 6, we declare ourselves unable to find a further refinement of the notion of cellularity that, in full generality, fixes both composability and existence of a terminal object. However, in the presheaf categories relevant to the motivating examples of Section 2, we are able to impose an additional *ad hoc* condition on top of cellularity which is sufficient to ensure that the cellular functors in this class both compose *and* admit a terminal object: using this, we finally obtain the desired notion of shapely monad, and are able to exhibit the monads encoding the graphical structures of interest as free shapely monads on the basic wiring operations of the structure.

2. MOTIVATING EXAMPLES

2.1. Some examples of graphical calculi. Before developing our general theory of shapeliness, we describe some of the examples of monads derived from graphical

calculi that our theory is intended to capture. The graphical calculi which we consider will involve diagrams built out of labelled boxes



with a finite number of “input” wires (positioned above the box) and “output” wires (positioned below). There are various interpretations we could give to such a box, for example:

- (i) As a derivation in a linear sequent calculus of $A_1, \dots, A_n \vdash B_1, \dots, B_m$;
- (ii) As a linear map $A_1 \otimes \cdots \otimes A_n \rightarrow B_1 \otimes \cdots \otimes B_m$ between k -vector spaces;
- (iii) As a program in the typed λ -calculus of type $A_1 \times \cdots \times A_n \rightarrow B_1 \times \cdots \times B_m$.

Each of these interpretations will be associated to a different graphical calculus; the difference between them is in the rules governing how boxes can be plugged together to form larger diagrams. For example:

- (i) Given proofs f of $C, D \vdash E, F, Z, I, J$ and g of $A, B, Z \vdash G, H$ in the linear sequent calculus, we can cut along the proposition Z to obtain a proof of $A, B, C, D \vdash E, F, G, H, I, J$. Thus, in the corresponding graphical calculus, we can plug together the boxes representing f and g to obtain a diagram:

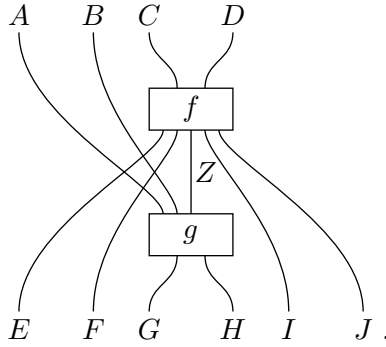

- (ii) Given k -linear maps $f: A \otimes B \rightarrow C$, $g: E \rightarrow F \otimes G$ and $h: C \otimes F \otimes G \rightarrow K$, we can consider the k -linear map $A \otimes E \otimes B \rightarrow K$ which sends $a \otimes e \otimes b$ to $h(f(a \otimes b) \otimes g(e))$. Thus, in the corresponding graphical calculus, we can plug together the boxes representing f , g and h to obtain a diagram:

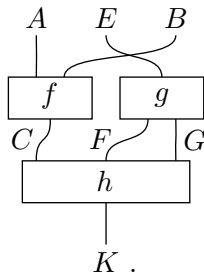

- (iii) Given programs $f: A \rightarrow B$ and $g: B \times A \rightarrow C$, there is a composite program $\lambda a. g(f(a), a): A \rightarrow C$; thus, in the corresponding graphical calculus, we can plug together the boxes for f and g to obtain a diagram:

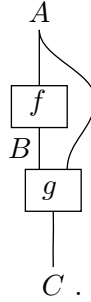

With a little further thought, we can derive from the intended interpretations of the boxes a description of the associated wiring discipline:

- (i) In the linear sequent calculus, we can only cut along a single formula, so that in the corresponding graphical calculus, we can only plug two boxes together along a single wire (output to input);
- (ii) In the case of linear maps between vector spaces, we can compose maps together over *multiple* tensor components, so that we can now plug multiple outputs of one box into multiple inputs of a second. We can also form the tensor product of two maps, corresponding to composing two boxes by placing them alongside each other.
- (iii) In the case of programs, we have the possibility of duplicating or discarding values; thus the corresponding graphical calculus will augment the rules from (ii) by allowing wires to split and terminate as they go down the page.

There are other possibilities; for example, intermediate between (i) and (ii) we have (ii)' which allows for plugging multiple inputs as in (ii) but does not allow for placing boxes alongside each other.

2.2. Algebraic structures from graphical calculi. In general, the purpose of graphical calculi is to provide a denotation system for elements in a semantic structure. For example, the graphical calculus in (ii) can be used to describe compound morphisms in the category of k -vector spaces, but more generally, in any symmetric monoidal category [19]; it is essentially the calculus of string diagrams in [17]. However, the calculus in (iii), with its more permissive wiring discipline, cannot be interpreted into k -vector spaces as there is no k -linear correlate to the operation of splitting or terminating wires.

There is a particularly canonical class of semantic structures into which a given graphical calculus can be interpreted; the structures in this class are built out of families of sets representing the wires and boxes of the graphical calculus, together with operations on those sets encoding the wiring discipline. For the graphical calculus in (i) above, these structures are the *polycategories* of [32]. These were explicitly introduced as semantic models for a two-sided propositional sequent calculus; although originally this was the classical Gentzen calculus,

it later became clear [24] that they encode precisely the sequent calculus of multiplicative linear logic.

Definition 2.1. A small (symmetric) polycategory \mathcal{C} comprises a set $\text{ob}(\mathcal{C})$ of objects; sets $\mathcal{C}(\mathbf{A}; \mathbf{B})$ of morphisms for each pair of lists $\mathbf{A} = (A_1, \dots, A_n)$ and $\mathbf{B} = (B_1, \dots, B_m)$ of objects; and the following further data:

- *Identity* morphisms $\text{id}_A \in \mathcal{C}(A; A)$ for each object A .
- *Composition* operations giving for each $f \in \mathcal{C}(\mathbf{A}; \mathbf{B})$ and $g \in \mathcal{C}(\mathbf{C}; \mathbf{D})$ and indices i, j with $B_i = C_j$, a morphism

$$g \circ_i f \in \mathcal{C}(\mathbf{C}_{<j}, \mathbf{A}, \mathbf{C}_{>j}; \mathbf{B}_{<i}, \mathbf{D}, \mathbf{B}_{>i});$$

here we use comma to denote concatenation of lists, and write $\mathbf{C}_{<j}$ for the list (C_1, \dots, C_{j-1}) , and so on.

- *Exchange* operations giving for each $f \in \mathcal{C}(\mathbf{A}; \mathbf{B})$ and permutations $\varphi \in \mathfrak{S}_n$ (the symmetric group on n letters) and $\psi \in \mathfrak{S}_m$ an element

$$\psi \cdot f \cdot \varphi \in \mathcal{C}(\mathbf{A}_\varphi; \mathbf{B}_{\psi^{-1}})$$

where \mathbf{A}_φ denotes the list $(A_{\varphi(1)}, \dots, A_{\varphi(n)})$ and likewise for $\mathbf{B}_{\psi^{-1}}$.

These data are required to satisfy the axioms of Definition 2.2 below.

If \mathcal{C} is a polycategory, then we think of elements of $\text{ob}(\mathcal{C})$ as wire-labels, and elements of $\mathcal{C}(\mathbf{A}; \mathbf{B})$ as boxes of the form (2.1). The operations of a polycategory now correspond to the elementary wiring operations on such boxes. The identity morphisms can be depicted as bare wires; composition $g \circ_i f$ as the plugging of the i th output of f into the j th input of g , as on the left below; and exchange as the rearrangement of input or output wires, as on the right below.

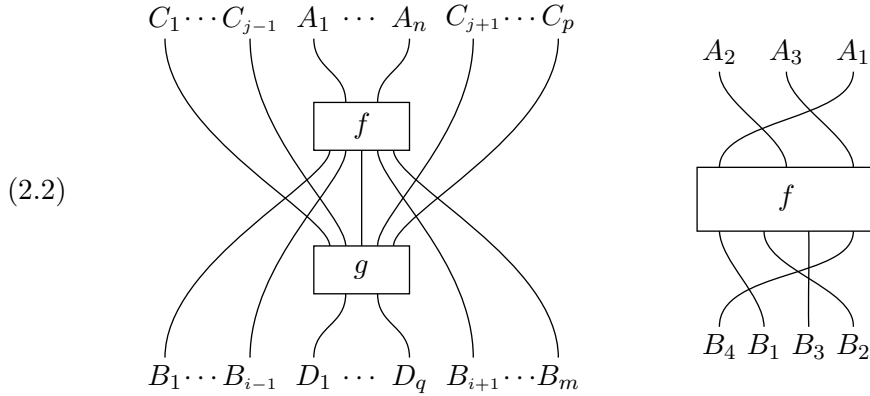

[Note that the identities of a polycategory involve only a single object rather than a list. A geometric explanation for this is that all the graphs occurring in polycategorical composition are *connected*, whereas the identity on a list of objects would be an unconnected graph.]

In terms of the graphical calculus, the axioms for a polycategory can be seen simply as asserting that various ways of wiring together a diagram of boxes coincide. We now give these axioms in full, mainly to show how unpalatable

they are when presented algebraically, and without any real expectation that the reader should work through the details.

Definition 2.2. The axioms for a polycategory \mathcal{C} are:

- The *unit* axioms:

$$f \circ_{i_1} \text{id}_{A_i} = f = \text{id}_{B_{j-1}} \circ_j f$$

for all $f \in \mathcal{C}(\mathbf{A}; \mathbf{B})$ and valid indices i, j .

- The *associativity* axiom:

$$(2.3) \quad (h \circ_{\ell} g) \circ_{\bar{j}} f = h \circ_{\bar{k}} (g \circ_j f)$$

for all $f \in \mathcal{C}(\mathbf{A}; \mathbf{B})$, $g \in \mathcal{C}(\mathbf{C}; \mathbf{D})$ and $h \in \mathcal{C}(\mathbf{E}; \mathbf{F})$ and all indices i, j, k, ℓ with $B_i = C_j$ and $D_k = E_\ell$. Here, $\bar{j} = j + \ell - 1$ and $\bar{k} = k + i - 1$.

- The *left interchange* axiom:

$$(h \circ_{k_2} g) \circ_{k_1} f = \psi \cdot ((h \circ_{k_1} f) \circ_{\bar{k}_2} g) .$$

for all $f \in \mathcal{C}(\mathbf{A}; \mathbf{B})$, $g \in \mathcal{C}(\mathbf{C}; \mathbf{D})$ and $h \in \mathcal{C}(\mathbf{E}; \mathbf{F})$ and all indices i, j and $k_1 < k_2$ such that $B_i = E_{k_1}$ and $D_j = E_{k_2}$. Here, $\bar{k}_2 = k_2 + n - 1$ where n is the length of the list \mathbf{A} , and ψ is the permutation for which $(\mathbf{B}_{<i}, \mathbf{D}_{<j}, \mathbf{F}, \mathbf{D}_{>j}, \mathbf{B}_{>i})_\psi = (\mathbf{D}_{<j}, \mathbf{B}_{<i}, \mathbf{F}, \mathbf{B}_{>i}, \mathbf{D}_{>j})$.

- The *right interchange* axiom:

$$g \circ_{j \circ_{i_1}} (h \circ_{k \circ_{i_2}} f) = (h \circ_{k \circ_{\bar{i}_2}} (g \circ_{j \circ_{i_1}} f)) \cdot \varphi .$$

for all $f \in \mathcal{C}(\mathbf{A}; \mathbf{B})$, $g \in \mathcal{C}(\mathbf{C}; \mathbf{D})$ and $h \in \mathcal{C}(\mathbf{E}; \mathbf{F})$ and all indices $i_1 < i_2$ and j, k such that $B_{i_1} = C_j$ and $B_{i_2} = E_k$. Here, $\bar{i} = i + m - 1$ where m is the length of the list \mathbf{D} , and φ is the permutation for which $(\mathbf{E}_{<k}, \mathbf{C}_{<j}, \mathbf{A}, \mathbf{C}_{>j}, \mathbf{E}_{>k})_\varphi = (\mathbf{C}_{<j}, \mathbf{E}_{<k}, \mathbf{A}, \mathbf{E}_{>k}, \mathbf{C}_{>j})$.

- The *action* axioms:

$$\text{id}_m \cdot f \cdot \text{id}_n = f \quad \text{and} \quad (\psi_2 \psi_1) \cdot f \cdot (\varphi_1 \varphi_2) = \psi_2 \cdot (\psi_1 \cdot f \cdot \varphi_1) \cdot \varphi_2$$

for all $f \in \mathcal{C}(\mathbf{A}; \mathbf{B})$ and suitable permutations $\varphi_1, \varphi_2, \psi_1$ and ψ_2 .

- The *equivariance of composition* axiom:

$$(\psi_2 \cdot g \cdot \varphi_2) \circ_{j \circ_i} (\psi_1 \cdot f \cdot \varphi_1) = \bar{\psi} \cdot (g \circ_{\varphi_2(j) \circ_{\psi_1^{-1}(i)}} f) \cdot \bar{\varphi}$$

for all $f \in \mathcal{C}(\mathbf{A}; \mathbf{B})$, $g \in \mathcal{C}(\mathbf{C}; \mathbf{D})$, and suitable permutations $\varphi_1, \varphi_2, \psi_1$ and ψ_2 . Here, $\bar{\varphi}$ is determined by $(\mathbf{C}_{<\varphi_2(j)}, \mathbf{A}, \mathbf{C}_{>\varphi_2(j)})_{\bar{\varphi}} = ((\mathbf{C}_{\varphi_2})_{<j}, \mathbf{A}_{\varphi_1}, (\mathbf{C}_{\varphi_2})_{>j})$ and $\bar{\psi}$ by $(\mathbf{B}_{<\psi_1^{-1}(i)}, \mathbf{D}, \mathbf{B}_{>\psi_1^{-1}(i)})_{\bar{\psi}^{-1}} = ((\mathbf{B}_{\psi_1^{-1}})_{<i}, \mathbf{D}_{\psi_2^{-1}}, (\mathbf{B}_{\psi_1^{-1}})_{>i})$.

In a similar way, we can associate algebraic structures to the other graphical calculi described above; since these calculi extend (i) with more permissive wiring disciplines, the associated structures extend polycategories with more permissive composition operations. For the calculi with wiring disciplines (ii)', (ii) and (iii), the structures obtained are, respectively (coloured) *properads* [35], (coloured) *PROPs* [27], and (many-sorted) *Lawvere theories* [25]. We now sketch the definitions for (ii)' and (ii), leaving (iii) as an exercise to the reader.

Definition 2.3. A *coloured properad* \mathcal{C} is given by the same data as for a polycategory, except for the operation of composition, which is generalised as follows. Given morphisms $f \in \mathcal{C}(\mathbf{A}; \mathbf{B})$ and $g \in \mathcal{C}(\mathbf{C}; \mathbf{D})$, and non-empty sequences of indices $I = \{i, \dots, i+k\}$ and $J = \{j, \dots, j+k\}$ such that $B_{i+\ell} = C_{j+\ell}$ for each $0 \leq \ell \leq k$, there is a composite morphism

$$(2.4) \quad g \circ_I f \in \mathcal{C}(\mathbf{C}_{<j}, \mathbf{A}, \mathbf{C}_{>j+k}; \mathbf{B}_{<i}, \mathbf{D}, \mathbf{B}_{>i+k}) .$$

These data satisfy axioms identical in form to Definition 2.2.

A *coloured PROP* \mathcal{C} is a coloured properad augmented with a morphism $0 \in \mathcal{C}(\ ; \)$ (representing the empty string diagram) and an operation which to morphisms $f \in \mathcal{C}(\mathbf{A}; \mathbf{B})$ and $g \in \mathcal{C}(\mathbf{C}; \mathbf{D})$, associates a morphism

$$(2.5) \quad g \circ_{\emptyset} f \in \mathcal{C}(\mathbf{A}, \mathbf{C}; \mathbf{B}, \mathbf{D}) ,$$

(representing f and g placed alongside each other), all subject to suitable axioms.

Of course, for each of these algebraic structures there is an associated notion of structure-preserving map giving the morphisms of a category:

Definition 2.4. If \mathcal{C} and \mathcal{D} are polycategories, then a *polyfunctor* $F: \mathcal{C} \rightarrow \mathcal{D}$ comprises an assignation on objects $F: \text{ob}(\mathcal{C}) \rightarrow \text{ob}(\mathcal{D})$ and assignations

$$\begin{aligned} \mathcal{C}(\mathbf{A}; \mathbf{B}) &\rightarrow \mathcal{D}(F\mathbf{A}; F\mathbf{B}) \\ f &\mapsto Ff \end{aligned}$$

on morphisms (where $F\mathbf{A} = (FA_1, \dots, FA_n)$ and similarly for $F\mathbf{B}$), such that for all suitable A, f, g, i, j, ψ and φ we have

$$F(\text{id}_A) = \text{id}_{FA} , \quad F(g \circ_j f) = Fg \circ_j Ff \quad \text{and} \quad F(\psi \cdot f \cdot \varphi) = \psi \cdot Ff \cdot \varphi .$$

We write **Polycat** for the category of small polycategories and polyfunctors. In a similar manner we have categories **Properad** and **Prop** of properads and PROPs.

2.3. Monads from graphical calculi. We now explain how the algebraic structures of the preceding section can be represented as algebras for suitable monads on a presheaf category. The presheaf category in question encodes the objects and morphisms of a polycategory, properad or PROP:

Definition 2.5. Let \mathbf{P} be the category with object-set $\{\star\} + \mathbb{N} \times \mathbb{N}$ and non-identity maps $\sigma_1^{n,m}, \dots, \sigma_n^{n,m}, \tau_1^{n,m}, \dots, \tau_m^{n,m}: \star \rightarrow (n, m)$ (we omit superscripts in the sequel for readability). A presheaf $X \in \mathcal{P}\mathbf{P}$ is called a *polygraph*¹, with elements of $X(\star)$ being called *vertices*, and elements of $X(n, m)$ *edges*. We write s_1, \dots, s_n and t_1, \dots, t_m for $X(\sigma_1), \dots, X(\sigma_n)$ and $X(\tau_1), \dots, X(\tau_m)$, and call the images of $e \in X(n, m)$ under these maps its *sources* and *targets* respectively.

There are forgetful functors from **Polycat**, **Properad** or **Prop** to $\mathcal{P}\mathbf{P}$ sending a polycategory, properad, or PROP to its underlying polygraph of objects and morphisms, and these functors are monadic, so allowing us to identify the structures at issue with algebras for the induced monad on $\mathcal{P}\mathbf{P}$. In fact, we may describe these monads explicitly; we now do this in detail for polycategories, and indicate how this should be adapted in the other cases.

¹Our usage follows [2]; note that these polygraphs are completely unrelated to those of [4].

The key observation is that objects of \mathcal{PP} can be seen as combinatorial representations of wiring diagrams of the kind drawn above. For instance, the diagram (2.1) for a box with n inputs and m outputs corresponds to the representable presheaf $y_{(n,m)} = \mathbf{P}(-, (n, m))$, while the diagram in (2.2) for a composite $g \circ_i f$ corresponds to a pushout

$$(2.6) \quad \begin{array}{ccc} y_{\star} & \xrightarrow{y_{\tau_i}} & y_{(n,m)} \\ y_{\sigma_j} \downarrow & & \downarrow u \\ y_{(p,q)} & \xrightarrow{v} & y_{(p,q)} \circ_i y_{(n,m)} \end{array}$$

in \mathcal{PP} . Writing $A = y_{(p,q)} \circ_i y_{(n,m)}$, the further composite $h \circ_{\bar{k}} (g \circ_i f)$ in the associativity axiom (2.3) corresponds to the pushout in \mathcal{PP} as to the left in:

$$\begin{array}{ccc} y_{\star} & \xrightarrow{y_{\tau_k}} & y_{(p,q)} & \xrightarrow{v} & A \\ y_{\sigma_\ell} \downarrow & & & & \downarrow \\ y_{(r,s)} & \xrightarrow{\quad} & y_{(r,s)} & \circ_{\bar{k}} & A \end{array} \quad \begin{array}{ccccc} & & y_{\star} & & y_{\star} \\ & & \swarrow & \searrow & \swarrow & \searrow \\ y_{(r,s)} & & & y_{(p,q)} & & y_{(n,m)} \end{array}$$

which is isomorphic to the polygraph representing $(h \circ_{\bar{k}} g) \circ_i f$, since both are colimits for the diagram above right. Iteratively taking pushouts of the preceding kind yields the following class of polygraphs describing the compound wiring operations of a polycategory; eventually, in Section 6.3 below, we will be able to generate all of these shapes from those for the basic wiring operations, but for the moment we give a more hands-on construction.

Definition 2.6. A *finite polygraph* is one with finitely many vertices and edges. An (n, m) -labelling of a finite polygraph is given by choices of vertices ℓ_1, \dots, ℓ_n and r_1, \dots, r_m , called the *leaves* and *roots* respectively. An *isomorphism* of labelled polygraphs is one respecting the labellings. Let $\mathcal{L}(n, m)$ be a set of isomorphism-class representatives of (n, m) -labelled finite polygraphs; we write $|X|$ for the underlying polygraph of $X \in \mathcal{L}(n, m)$ and ℓ^X and r^X for the labellings. Now:

- (a) Let $\text{id} \in \mathcal{L}(1, 1)$ be y_{\star} labelled in the unique possible way;
- (b) Given $X \in \mathcal{L}(n, m)$, $Y \in \mathcal{L}(p, q)$ and indices $1 \leq i \leq m$ and $1 \leq j \leq p$, let $Y \circ_i X \in \mathcal{L}(n + p - 1, m + q - 1)$ be such that there is a pushout of underlying polygraphs

$$(2.7) \quad \begin{array}{ccc} y_{\star} & \xrightarrow{r_i^X} & |X| \\ \ell_j^Y \downarrow & & \downarrow u \\ |Y| & \xrightarrow{v} & |Y \circ_i X| \end{array}$$

with the labelling of the leaves and roots given respectively by:

$$\begin{aligned} & v\ell_1^Y, \dots, v\ell_{j-1}^Y, \quad u\ell_1^X, \dots, u\ell_n^X, \quad v\ell_{j+1}^Y, \dots, v\ell_p^Y \\ \text{and} \quad & ur_1^X, \dots, ur_{i-1}^X, \quad vr_1^Y, \dots, vr_q^Y, \quad ur_{i+1}^X, \dots, ur_m^X. \end{aligned}$$

- (c) For any $X \in \mathcal{L}(n, m)$, $\varphi \in \mathfrak{S}_n$ and $\psi \in \mathfrak{S}_m$, let $\psi \cdot X \cdot \varphi \in \mathcal{L}(n, m)$ be $|X|$ labelled by $\ell_{\varphi(1)}, \dots, \ell_{\varphi(n)}$ and $r_{\psi^{-1}(1)}, \dots, r_{\psi^{-1}(m)}$.
- (d) For each $n, m \in \mathbb{N}$, let $\langle n, m \rangle \in \mathcal{L}(n, m)$ be $y_{(n,m)}$ labelled by $y_{\sigma_1}, \dots, y_{\sigma_n}$ and $y_{\tau_1}, \dots, y_{\tau_m}$.

Now let $\mathcal{T}(n, m) \subset \mathcal{L}(n, m)$ be the subsets obtained by closing the elements $\langle n, m \rangle$ in (d) under the operations in (a)–(c).²

As noted above, the labelled polygraphs in the sets $\mathcal{T}(n, m)$ represent the compound wiring operations of a polycategory; following [20, 21], we may characterise them in a direct combinatorial manner.

Definition 2.7. For any polygraph X , we write G_X for the undirected multigraph obtained as follows: the nodes are the disjoint union of the sets of edges and of vertices of X , and there is an arc $v \frown e$ for each way that v is a source or a target of e . A polygraph X is called a *polycategorical tree* if it has finitely many edges and vertices, and moreover:

- Each vertex of X is a source of at most one edge;
- Each vertex of X is a target of at most one edge;
- G_X is acyclic (in particular without multiple edges) and connected (in particular non-empty).

A *labelled polycategorical tree* is a polycategorical tree equipped with an (n, m) -labelling for which ℓ_1, \dots, ℓ_n enumerate the *inputs*, i.e., the vertices which are not the targets of any edge, and r_1, \dots, r_m enumerate *outputs*, i.e., the vertices which are not the source of any edge.

Lemma 2.8. $\mathcal{T}(n, m)$ is the set of isomorphism-class representatives of (n, m) -labelled polycategorical trees.

Proof. Each $\langle n, m \rangle$ is a labelled polycategorical tree, and labelled polycategorical trees are closed under (a)–(c) above. Thus, (n, m) -labelled polycategorical trees contain all of $\mathcal{T}(n, m)$. Conversely, we may show that any labelled polycategorical tree T is in $\mathcal{T}(n, m)$ by induction on the number of edges in T . If T contains no edge, then it must be $\text{id} \in \mathcal{T}(1, 1)$. If $|T| = e$, then $T \in \mathcal{T}(n, m)$ by (c)–(d). Otherwise, by acyclicity and finiteness, we may find an edge e whose sources are not targets of any edge. Removing e from T , together with any isolated vertices that this creates, leaves us with a positive number of connected components T_1, \dots, T_p which all contain at least one edge. By acyclicity, e is linked to each T_j through exactly one vertex. If $p = 1$, then T is a composite of T_1 and e . Otherwise, let T' denote T with T_p and any consequent isolated vertices removed; by the inductive hypothesis, T' is in $\mathcal{T}(n', m')$, where n' and m' respectively denote the numbers of inputs and outputs of T' , and T is a composite of T_p and T' . This completes the proof. \square

²Note that implicit in these definitions are the assumptions that the elements id and $\langle n, m \rangle$ of (a) and (d) are the chosen representatives of their isomorphism-classes, and that relabelling a representative $X \in \mathcal{L}(n, m)$ as in (c) yields another such; we are clearly at liberty to make these assumptions.

The labelled polycategorical trees may now be used to provide a concrete description of the left adjoint $F_{\mathbb{P}}$ to $U: \mathbf{Polycat} \rightarrow \mathscr{P}\mathbb{P}$. Given Lemma 2.8, the proof of the following result is straightforward, if tedious; the reader may reconstruct it by suitably adapting [28, Proposition 1.9.2] or [20, §2.2.7].

Proposition 2.9. *The free polycategory $F_{\mathbb{P}}X$ on a polygraph $X \in \mathscr{P}\mathbb{P}$ has object set $X(\star)$ and morphism sets $(F_{\mathbb{P}}X)(v_1, \dots, v_n; w_1, \dots, w_m)$ given by*

$$(2.8) \quad \sum_{T \in \mathscr{T}(n,m)} \{ f: |T| \rightarrow X \text{ in } \mathscr{P}\mathbb{P} : f(\ell_i^T) = v_i \text{ and } f(r_j^T) = w_j \} .$$

The identity morphism in $(F_{\mathbb{P}}X)(v; v)$ is the pair $(\text{id} \in \mathscr{T}(1, 1), v: y_{\star} \rightarrow X)$; the composite $(S, f) \circ_i (T, g)$ is given by $(S \circ_i T, f \circ_i g)$, where $f \circ_i g$ is the unique map out of the pushout (2.7) induced by f and g ; and the exchange operation is defined by $\psi \cdot (T, f) \cdot \varphi = (\psi \cdot T \cdot \varphi, f)$.

We may proceed in a similar manner to obtain explicit descriptions of the monads for properads and for PROPs on $\mathscr{P}\mathbb{P}$. In the case of properads, we generalise the labelled polycategorical trees to labelled *properadic graphs*, by modifying clause (b) of Definition 2.7 so as to allow for pushouts of the form

$$\begin{array}{ccc} y_{\star} + \dots + y_{\star} & \xrightarrow{\langle r_i^X, \dots, r_{i+k}^X \rangle} & |X| \\ \langle \ell_j^X, \dots, \ell_{j+k}^X \rangle \downarrow & & \downarrow u \\ |Y| & \xrightarrow{v} & |Y \circ_I X| . \end{array}$$

We may now modify Lemma 2.8 to characterise the properadic graphs by requiring G_X to be acyclic as a *directed* graph, though still connected as an *undirected* graph. With this modification, Proposition 2.9 carries through, to give an explicit description of the monad for properads on $\mathscr{P}\mathbb{P}$.

PROPs may almost be treated in the same way. We can augment Definition 2.6 suitably to obtain the class \mathscr{G} of *graphs for PROPs*, and then modify Lemma 2.8 to obtain a combinatorial characterisation of these graphs; in this case G_X need only be acyclic as a directed graph, as in [17]. However, the formula for the morphism sets of the free PROP is not quite given by the obvious adaptation of (2.8). This is essentially because the axioms for a PROP are susceptible to the well-known *Eckmann–Hilton argument* [?]; among other things, this implies that for any PROP \mathscr{C} and any $f, g \in \mathscr{C}(\ ; \)$, we have $g \circ_{\emptyset} f = f \circ_{\emptyset} g$:

$$\boxed{f} \quad \boxed{g} \quad = \quad \boxed{g} \quad \boxed{f} \quad .$$

Since the shape of the composition just depicted is encoded by the graph for PROPs $R = \langle 0, 0 \rangle_{\emptyset} \bullet_{\emptyset} \langle 0, 0 \rangle \in \mathscr{G}(0, 0)$ with underlying presheaf $|R| = y_{(0,0)} + y_{(0,0)}$, the formula for the free PROP $F_{\mathbb{P}}X$ on a polygraph X must differ from (2.8) in identifying, among other things, the pair of elements $\langle f, g \rangle: |R| \rightarrow X$ and $\langle g, f \rangle: |R| \rightarrow X$ in $(F_{\mathbb{P}}X)(\ ; \)$ for any $f, g \in X(\ ; \)$. This is an instance of a more general phenomenon: each graph for PROPs $T \in \mathscr{G}(n, m)$ may admit a non-trivial group \mathfrak{S}_T of label-preserving automorphisms (permuting unlabelled

isomorphic connected components), and the construction of the free PROP must quotient out by the action of these automorphisms.

Proposition 2.10. *The free PROP $F_{\mathbb{P}}X$ on $X \in \mathcal{PP}$ has object set $X(\star)$ and morphism sets $(F_{\mathbb{P}}X)(v_1, \dots, v_n; w_1, \dots, w_m)$ given by*

$$\sum_{T \in \mathcal{G}(n,m)} \{f: |T| \rightarrow X \text{ in } \mathcal{PP} : f(\ell_i^T) = v_i, f(r_j^T) = w_j\} / \mathfrak{S}_T$$

with remaining structure defined analogously to Proposition 2.9 above.

2.4. An alternative presentation. There is another way of presenting polycategories, properads and PROPs as the algebras for a monad on a presheaf category. Though it is further away from the graphical intuition, it is quite a common approach in mathematical practice, and still fits into the general framework we will develop; it therefore seems to be worth describing here. The idea is to incorporate the exchange operations into the underlying presheaf:

Definition 2.11. Let \mathbb{P}_s be the category obtained from \mathbb{P} by adjoining arrows $\xi_{\varphi, \psi}: (n, m) \rightarrow (n, m)$ for each $\varphi \in \mathfrak{S}_n$ and $\psi \in \mathfrak{S}_m$, subject to the equations:

$$\begin{aligned} \xi_{\text{id}_n, \text{id}_m} &= \text{id}_{(n,m)} & \xi_{\varphi_1, \psi_1} \circ \xi_{\varphi_2, \psi_2} &= \xi_{\varphi_1 \varphi_2, \psi_2 \psi_1} \\ \xi_{\varphi, \psi} \circ \sigma_i &= \sigma_{\varphi(i)} & \xi_{\varphi, \psi} \circ \tau_{\psi(j)} &= \tau_j . \end{aligned}$$

A presheaf $X \in \mathcal{PP}_s$ is called a *symmetric polygraph*.

Like before, there are monadic forgetful functors from **Polycat**, **Properad** and **Prop** to \mathcal{PP}_s . In the case of polycategories, the left adjoint can now be described using labelled *symmetric* polycategorical trees. Let $\mathcal{L}_s(n, m)$ and $\mathcal{T}_s(n, m)$ be defined exactly like $\mathcal{L}(n, m)$ and $\mathcal{T}(n, m)$ in Definition 2.6 but working over the category \mathcal{PP}_s of symmetric polygraphs. Since each symmetric polygraph $y_{(n,m)}$ has *free* action by $\mathfrak{S}_n \times \mathfrak{S}_m^{\text{op}}$, the same will be true of the underlying symmetric polygraph of any $T \in \mathcal{T}_s(n, m)$; in fact, these T 's are precisely the images³ of the non-symmetric trees in $\mathcal{T}(n, m)$ under the free functor $\mathcal{PP} \rightarrow \mathcal{PP}_s$. Just as we saw when considering graphs for PROPs in the previous section, symmetric labelled trees $T \in \mathcal{T}_s(n, m)$ may admit non-trivial groups \mathfrak{S}_T of label-preserving automorphisms, and the construction of the free polycategory must quotient out by these in the same way.

Proposition 2.12. *The free polycategory $F_{\mathbb{P}_s}X$ on $X \in \mathcal{PP}_s$ has object set $X(\star)$ and morphism sets $(F_{\mathbb{P}_s}X)(v_1, \dots, v_n; w_1, \dots, w_m)$ given by*

$$\sum_{T \in \mathcal{T}_s(n,m)} \{f: |T| \rightarrow X \text{ in } \mathcal{PP}_s : f(\ell_i^T) = v_i, f(r_j^T) = w_j\} / \mathfrak{S}_T$$

with remaining structure defined analogously to Proposition 2.9 above.

Exactly the same considerations apply to the cases of properads and PROPs; note that, in the properadic case, the description of the free properad monad so obtained is that of [21].

³Though note that non-isomorphic elements of $\mathcal{T}(n, m)$ may become isomorphic in $\mathcal{T}_s(n, m)$.

3. FAMILIAL FUNCTORS AND SHAPELINESS

Now that we have described various “graphically specified” structures as algebras for monads on presheaf categories, we begin our attempts to obtain these monads via a notion of shapeliness. As in the introduction, our approach will be to seek on the appropriate presheaf category a *universal* shapely monad \mathbf{U} with “exactly one operation of each shape”, and to generate the monad encoding the given structure as a suitable submonad of \mathbf{U} . In this section, we look for \mathbf{U} as a terminal object among *familiably representable*, or more shortly *familial*, endofunctors—ones which pointwise are coproducts of representables. While this turns out not quite to work, the techniques we develop will be crucial to our subsequent efforts.

3.1. Linear operations and familial functors. The key concept underlying the notion of familial functor is that of a *linear operation*.

Definition 3.1. Given a functor $F: \mathcal{A} \rightarrow \mathcal{B}$ and objects $A \in \mathcal{A}$ and $B \in \mathcal{B}$, an *F-operation of input arity A at stage B* is a map $t: B \rightarrow FA$. An *F-operation* t is *linear* if it is initial in its connected component of the comma category $B \downarrow F$.

An operation $t: B \rightarrow TA$ of a monad \mathbf{T} on \mathcal{A} corresponds to a family of interpretation functions $\llbracket t \rrbracket: \mathcal{A}(A, X) \rightarrow \mathcal{A}(B, X)$, one for each \mathbf{T} -algebra (X, x) ; maps of $B \downarrow T$ account for reindexing such \mathbf{T} -operations so as to act only on part of their input arity, so that linearity expresses the idea of an operation which “consumes all its input arity”.

Lemma 3.2. *An operation $t: B \rightarrow FA$ is linear if and only if for every square of the following form, there is a unique $h: A \rightarrow A'$ with $Fh.t = u$; it then follows also that $fh = g$.*

$$(3.1) \quad \begin{array}{ccc} B & \xrightarrow{u} & FA' \\ t \downarrow & \nearrow Fh & \downarrow Ff \\ FA & \xrightarrow{Fg} & FA'' \end{array}$$

Proof. This is [6, Proposition 0]. □

Now a *familial* functor is one whose operations are all reindexings of linear ones. In giving the definition, we say that Y *covers* X if there is a map $Y \rightarrow X$.

Definition 3.3. A functor $F: \mathcal{A} \rightarrow \mathcal{B}$ is *familial at stage* $B \in \mathcal{B}$ if each operation in $B \downarrow F$ is covered by a linear one; a transformation $\alpha: F \Rightarrow G$ is *familial at stage* B if F and G are so, and the induced functor $B \downarrow F \rightarrow B \downarrow G$ preserves linear operations. We write simply *familial* to mean “familial at every stage”.

Familial functors were introduced by Diers [6]; his terminology is that familial functors are those “having a left multiadjoint”. Our name is a shortening of the term “familiably representable” used—for the special case $\mathcal{B} = \mathbf{Set}$ —in [15].

Lemma 3.4. *A functor $F: \mathcal{A} \rightarrow \mathcal{B}$ is familial at stage $B \in \mathcal{B}$ if and only if the functor $\mathcal{B}(B, F-): \mathcal{A} \rightarrow \mathbf{Set}$ is a (possibly large) coproduct of representables.*

Proof. F is familial at stage B just when $B \downarrow F$ is a coproduct of categories with initial objects. This is to say that there is an I -indexed family of elements $\{t_i \in \mathcal{B}(B, FA_i) : i \in I\}$ such that any $f \in \mathcal{B}(B, FA)$ factors as $f = F\bar{f} \circ t_i$ for a unique $i \in I$ and $\bar{f}: A_i \rightarrow A$; or equally, that $\mathcal{B}(B, F-) \cong \sum_i \mathcal{A}(A_i, -)$. \square

3.2. Pointwise familiarity. We will be interested in familial endofunctors of presheaf categories; later, we will need more general familial functors with *codomain* a presheaf category. The most relevant kind of familiarity for these is:

Definition 3.5. A functor $F: \mathcal{A} \rightarrow \mathcal{P}\mathcal{C}$ or transformation $\alpha: F \Rightarrow G: \mathcal{A} \rightarrow \mathcal{P}\mathcal{C}$ is *pointwise familial* if it is familial at all representable stages $y_c \in \mathcal{P}\mathcal{C}$; while F is called *small* if $y_c \downarrow F$ has a mere *set* of connected components for each $c \in \mathcal{C}$. We write $\mathbf{FAM}_{\text{pt}}(\mathcal{A}, \mathcal{P}\mathcal{C})$ for the category of small pointwise familial functors and pointwise familial transformations.

By Lemma 3.4, $F: \mathcal{A} \rightarrow \mathcal{P}\mathcal{C}$ is (small) pointwise familial just when each functor $(F-)c \in [\mathcal{A}, \mathbf{Set}]$ can be expressed as

$$(3.2) \quad (F-)c \cong \sum_{t \in Sc} \mathcal{A}(Et, -)$$

for some set Sc and family of objects $(Et \in \mathcal{A})_{t \in Sc}$. So, for example, the “free polycategory” endofunctor on the category \mathcal{PP} of polygraphs as in Proposition 2.9 is pointwise familial, but the corresponding endofunctor on the category \mathcal{PP}_s of symmetric polygraphs is *not* so, as it involves not just coproducts of representables but also quotients by group actions. We will be able to handle the latter example when we consider *analytic* functors in the following section.

We now explain how (3.2) allows us to give a compact representation for pointwise familial functors. Such a functor F is determined to within isomorphism by the sets Sc and objects $(Et \in \mathcal{A})_{t \in Sc}$ as in (3.2), as c ranges over $\text{ob}(\mathcal{C})$, together with information about how these transform under each $(F-)f: (F-)d \rightarrow (F-)c$. More precisely, $(F-)f$ may be identified with a transformation

$$(3.3) \quad \sum_{t \in Sd} \mathcal{A}(Et, -) \rightarrow \sum_{s \in Sc} \mathcal{A}(Eu, -);$$

and, by the Yoneda lemma, to specify this is equally to specify a function $Sf: Sd \rightarrow Sc$, together with a family of maps $(E(Sf(t)) \rightarrow E(t) \in \mathcal{A})_{t \in Sd}$.

Functoriality in f of the maps (3.3) tell us that these data determine, firstly, a presheaf $S \in \mathcal{P}\mathcal{C}$; and secondly, a functor $E: \text{el } S \rightarrow \mathcal{P}\mathcal{C}$. Here $\text{el } S$ is the *category of elements* of the presheaf S , whose object-set is given by $\sum_{c \in \mathcal{C}} Sc$ and whose maps from $s \in Xc$ to $t \in Xd$ are maps $f \in \mathcal{C}(c, d)$ with $s = (Sf)(t)$.

In fact, giving S and E of this form is equivalent to giving a small pointwise familial functor $\mathcal{A} \rightarrow \mathcal{P}\mathcal{C}$; this can be made precise by constructing an equivalence between $\mathbf{FAM}_{\text{pt}}(\mathcal{A}, \mathcal{P}\mathcal{C})$ and the following category, which is the “ \mathcal{C} -**Fam**(\mathcal{A})” of [36, Definition 2.10].

Definition 3.6. For any \mathcal{A} and small \mathcal{C} , the category $\text{el}_{\mathcal{C}} // \mathcal{A}$ has as objects, pairs of a presheaf $S \in \mathcal{P}\mathcal{C}$ and a functor $E: \text{el } S \rightarrow \mathcal{A}$, and as maps $(S, E) \rightarrow (T, D)$,

pairs of a presheaf map $p: S \rightarrow T$ and a natural isomorphism φ of the form:

$$(3.4) \quad \begin{array}{ccc} \text{el } S & \xrightarrow{\text{el } p} & \text{el } T \\ & \searrow \varphi \swarrow & \\ E & \xrightarrow{\quad} & D \\ & \swarrow \varphi \searrow & \\ & \mathcal{A} & \end{array}$$

A little care is necessary in order to extract the pair (S, E) from a small pointwise familial F . Observe first that *choosing* an isomorphism (3.2) is equivalent to *choosing* a linear operation in each connected component of $y_c \downarrow F$. Having done so, S_c can be taken to be the set of these chosen linear operations, and $(Et \in \mathcal{A})_{t \in S_c}$ to be the family of input arities of these operations. Henceforth, we assume that each $F \in \mathbf{FAM}_{\text{pt}}(\mathcal{A}, \mathcal{P}\mathcal{C})$ is equipped with such choices of linear operation; for any $t \in y_c \downarrow F$, we write \tilde{t} for the chosen linear operation which covers it. In light of the preceding discussion, it is now natural to define:

Definition 3.7. The *spectrum* [6, Definition 3] of a small pointwise familial $F: \mathcal{A} \rightarrow \mathcal{P}\mathcal{C}$ is the presheaf $S_F \in \mathcal{P}\mathcal{C}$ given by:

$$S_F(c) = \{t \in y_c \downarrow F : \tilde{t} = t\} \quad \text{and} \quad S_F(f: d \rightarrow c): t \mapsto \widetilde{ty}_f.$$

The *canonical diagram* of F is the functor $D_F: \text{el } S_F \rightarrow \mathcal{P}\mathcal{C} \downarrow F$ with:

$$D_F(t) = \begin{array}{c} y_c \\ \downarrow t \\ FA \end{array} \quad \text{and} \quad D_F(f: \widetilde{ty}_f \rightarrow t) = \begin{array}{ccc} y_c & \xrightarrow{y_f} & y_d \\ \widetilde{ty}_f \downarrow & & \downarrow t \\ FA' & \xrightarrow{Fu_f} & FA \end{array},$$

where the lower right map is uniquely induced by linearity of \widetilde{ty}_f . The *exponent* [37, Definition 7.1] of F is the functor $E_F: \text{el } S_F \rightarrow \mathcal{A}$ obtained by composing the canonical diagram with the second projection $\pi_2: \mathcal{P}\mathcal{C} \downarrow F \rightarrow \mathcal{A}$.

As elements of $S_F(c)$ are in bijection with connected components of $y_c \downarrow F$, the presheaf S_F is equally the colimit of F ; smallness is just what is needed to ensure this colimit exists. In particular, smallness is vacuous when either \mathcal{A} is small or \mathcal{A} has a terminal object, and in the latter case, we may take $S_F = F1$.

Proposition 3.8. *The assignment $F \mapsto (S_F, E_F)$ is the action on objects of an equivalence of categories between $\mathbf{FAM}_{\text{pt}}(\mathcal{A}, \mathcal{P}\mathcal{C})$ and $\text{el}_{\mathcal{C}} \parallel \mathcal{A}$.*

Proof. This is a generalisation of [36, Theorem 2.18], and we argue largely as there. First let $\alpha: F \Rightarrow G$ in $\mathbf{FAM}_{\text{pt}}(\mathcal{A}, \mathcal{P}\mathcal{C})$. To give the transformation α is to give transformations $\alpha_c: (F-)c \Rightarrow (G-)c$ naturally in c ; since by Lemma 3.4 the functor $(F-)c$ is a coproduct of representables, giving each α_c is equivalent to giving the G -linear operation $\alpha_{A,t}: y_c \rightarrow GA$ obtained by acting α on each chosen F -linear operation $t: y_c \rightarrow FA$. But $\alpha_{A,t}$ factorises as on the left in:

$$(3.5) \quad \begin{array}{ccc} p(t) := \widetilde{\alpha_{A,t}} & y_c & \\ & \swarrow \alpha_{A,t} \searrow & \\ GA' & \xrightarrow{G\varphi_t} & GA \end{array} \quad \begin{array}{ccc} \text{el } S_F & \xrightarrow{\text{el } p} & \text{el } S_G \\ & \searrow \varphi \swarrow & \\ E_F & \xrightarrow{\quad} & E_G \\ & \swarrow \varphi \searrow & \\ & \mathcal{A} & \end{array}$$

using the chosen linear operations of G , and linearity of $\alpha_A.t$ is equivalent to each φ_t being invertible: indeed, linear operations are closed under isomorphism in $y_c \downarrow G$, and any morphism between linear operations is invertible. Thus, to give the pointwise familial α is equally to specify for each chosen linear $t \in y_c \downarrow F$ a chosen linear $p(t) \in y_c \downarrow G$ together with an isomorphism $\varphi_t: E_G(p(t)) \rightarrow E_F(t)$. All this must be done naturally in c so that to give α is equally to give a pair (p, φ) as right above with φ invertible.

This defines $\mathbf{FAM}_{\text{pt}}(\mathcal{A}, \mathcal{P}\mathcal{C}) \rightarrow \text{el}_{\mathcal{C}} // \mathcal{A}$ on morphisms and simultaneously shows that it is fully faithful (functoriality follows from uniqueness in Lemma 3.2). It remains to prove essential surjectivity. Given $S \in \mathcal{P}\mathcal{C}$ and $E: \text{el } S \rightarrow \mathcal{A}$, define a functor $F: \mathcal{A} \rightarrow \mathcal{P}\mathcal{C}$ by taking $(F-)c = \sum_{t \in S_c} \mathcal{A}(Et, -)$ and taking $(F-)(f: d \rightarrow c)$ to be the unique natural transformation rendering commutative each diagram:

$$\begin{array}{ccc} \mathcal{A}(Et, -) & \xrightarrow{\mathcal{A}(Ef, -)} & \mathcal{A}(E(tf), -) \\ \downarrow \iota & & \downarrow \iota \\ \sum_{t \in S_c} \mathcal{A}(Et, -) & \xrightarrow{(F-)f} & \sum_{u \in S_d} \mathcal{A}(Eu, -) . \end{array}$$

By Lemma 3.4, F is pointwise familial, and is moreover small since the coproduct defining $(F-)c$ is so; now by choosing the linear operations in $y_c \downarrow F$ to be those $\gamma_t: y_c \rightarrow FEt$ picking out the pairs $(t, 1_{Et})$, we have a bijection $S \rightarrow S_F$ sending t to γ_t , which, since $E_F(\gamma_t) = Et$, commutes *strictly* with the functors to \mathcal{A} . \square

3.3. Composition of familial functors. In seeking a universal shapely monad among the class of familial endofunctors, we must consider both composability and existence of a terminal object; we start with composability. The following lemma gives the properties of linear operations necessary to establish our results.

Lemma 3.9. *Let $F: \mathcal{A} \rightarrow \mathcal{B}$ and $G: \mathcal{B} \rightarrow \mathcal{C}$ be functors.*

- (i) *If $s: C \rightarrow GB$ is G -linear and $t: B \rightarrow FA$ is F -linear, then the composite $Gt.s: C \rightarrow GB \rightarrow GFA$ is GF -linear.*
- (ii) *The full subcategory $\mathbf{Lin}(\mathcal{B} \downarrow F) \subset \mathcal{B} \downarrow F$ on the linear operations is closed under pointwise colimits (ones created by the projection $\mathcal{B} \downarrow F \rightarrow \mathcal{B} \times \mathcal{A}$).*

Proof. A short calculation using Lemma 3.2. \square

Now, in order to show that the composite of $F: \mathcal{A} \rightarrow \mathcal{B}$ and $G: \mathcal{B} \rightarrow \mathcal{C}$ is familial at stage C , we should like to take the linear operations of the composite to be of the form $Gt.s$ for s and t as in (i) above. In order for this to work, we need to be able to cover any operation $C \rightarrow GFX$ by some operation of this form. This suggests that, if GF is to be familial at stage C , then the input arity of each G -linear operation at stage C should be a stage of familiarity for F , as in the following definition.

Definition 3.10. Given $\mathcal{A}' \subset \mathcal{A}$ and $\mathcal{B}' \subset \mathcal{B}$ full replete subcategories, we say that $F: \mathcal{A} \rightarrow \mathcal{B}$ is $(\mathcal{A}', \mathcal{B}')$ -familial if it is familial at each stage $B \in \mathcal{B}'$ and each linear $t \in B \downarrow F$ has input arity in \mathcal{A}' . A transformation $\alpha: F \Rightarrow G$ between such functors is $(\mathcal{A}', \mathcal{B}')$ -familial if it is familial at every stage $B \in \mathcal{B}'$.

In this terminology, a familial functor $F: \mathcal{A} \rightarrow \mathcal{B}$ is equally $(\mathcal{A}, \mathcal{B})$ -familial, while a pointwise familial functor $\mathcal{A} \rightarrow \mathcal{P}\mathcal{C}$ is equally an $(\mathcal{A}, \mathcal{Y}\mathcal{C})$ -familial one. The next result improves in very mild ways on [6, p. 985] and [37, Corollary 5.15].

Proposition 3.11. *If $F: \mathcal{A} \rightarrow \mathcal{B}$ and $G: \mathcal{B} \rightarrow \mathcal{C}$ are $(\mathcal{A}', \mathcal{B}')$ - and $(\mathcal{B}', \mathcal{C}')$ -familial, then their composite is $(\mathcal{A}', \mathcal{C}')$ -familial, and has as linear operations at stage $C \in \mathcal{C}'$ precisely the composites $Gt.s: C \rightarrow GB \rightarrow GFA$ of G - and F -linear operations. The correspondingly familial transformations between these functors are likewise composable; in particular, there is a 2-category **FAM** of categories, familial functors and familial transformations.*

Proof. Because all linear coverings of an operation are isomorphic and \mathcal{A}' is replete, to show that GF is $(\mathcal{A}', \mathcal{C}')$ -familial it suffices to show that any $s: C \rightarrow GFX$ with $C \in \mathcal{C}'$ is covered in $C \downarrow GF$ by some linear operation with input arity in \mathcal{A}' . But we have successive factorisations

$$\begin{array}{ccc} & C & \\ \tilde{s} \swarrow & & \searrow s \\ GB & \xrightarrow{Gt} & GFX \end{array} \quad \begin{array}{ccc} & B & \\ \tilde{t} \swarrow & & \searrow t \\ FA & \xrightarrow{Ff} & FX \end{array}$$

with $B \in \mathcal{B}'$ and $A \in \mathcal{A}'$ by applying familiarity of G to s and of F to t . By Lemma 3.9(i), the composite $G\tilde{t}.\tilde{s}$ is GF -linear so that $f: G\tilde{t}.\tilde{s} \rightarrow s$ is the required cover. That all linear operations have this shape follows by Lemma 3.2. Stability under composition follows from the previous points and naturality. \square

Since we are really interested in pointwise familial functors between presheaf categories, we should like to know that these, too, are closed under composition. The key to showing this is the following result.

Proposition 3.12. *Let \mathcal{A} be cocomplete. For any functor $F: \mathcal{A} \rightarrow \mathcal{B}$ or transformation $\alpha: F \Rightarrow G$, the full subcategory $\mathcal{B}' \subset \mathcal{B}$ whose objects are those stages $B \in \mathcal{B}$ at which F (respectively α) is familial is closed in \mathcal{B} under colimits.*

Proof. Suppose given $F: \mathcal{A} \rightarrow \mathcal{B}$, a diagram $D: \mathcal{I} \rightarrow \mathcal{B}$ such that F is familial at each $DI \in \mathcal{B}$, and a colimiting cocone $(p_I: DI \rightarrow V)_{I \in \mathcal{I}}$; we must show that F is also familial at V . So let $t: V \rightarrow FA$, and consider the diagram of linear operations $D_t: \mathcal{I} \rightarrow \mathcal{B} \downarrow F$ defined by:

$$D_t(I) = \begin{array}{c} DI \\ \widetilde{tp}_I \downarrow \\ FA_I \end{array} \quad D_t(f: I \rightarrow J) = \begin{array}{ccc} DI & \xrightarrow{Df} & DJ \\ \widetilde{tp}_I \downarrow & & \downarrow \widetilde{tp}_J \\ FA_I & \xrightarrow{Fu_f} & FA_J \end{array}$$

where the map u_f is the unique one induced by linearity of \widetilde{tp}_I . Since \mathcal{A} is cocomplete, the diagram D_t admits a pointwise colimit $u: V \rightarrow FW$, which by Lemma 3.9(ii) is itself linear. There is a cocone $D_t \Rightarrow \Delta t$ with components $(p_I, q_I): \widetilde{tp}_I \rightarrow t$ where the maps q_I are, again, induced by linearity of \widetilde{tp}_I , and this now induces a map $u \rightarrow t$ in $V \downarrow F$ providing the desired linear cover of t . This shows F is familial at V , and also that $t \in V \downarrow F$ is linear just when

its cocone $(p, q): D_t \Rightarrow \Delta t$ is colimiting; this last fact entails the part of the proposition concerned with transformations α . \square

As every presheaf is a colimit of representables, we immediately conclude from the preceding two results that:

Corollary 3.13. *If \mathcal{A} is cocomplete, then each pointwise familial functor or transformation in $\mathbf{FAM}_{\text{pt}}(\mathcal{A}, \mathcal{P}\mathcal{C})$ is familial; whence there is a 2-category \mathbf{FAM}_{pt} of presheaf categories and pointwise familial functors and transformations.*

In the next section, size considerations will force us to bound the input arities of the pointwise familial functors we consider. As we would still like such functors to compose, we introduce the relevant notions and prove composability here.

Definition 3.14. We write $\mathcal{F}\mathcal{C} \subset \mathcal{P}\mathcal{C}$ for the full, replete subcategory of *finitely presentable* presheaves: those expressible as a finite colimit of representables. A pointwise familial functor $\mathcal{P}\mathcal{C} \rightarrow \mathcal{P}\mathcal{D}$ is called *finitary* if it is $(\mathcal{F}\mathcal{C}, \mathcal{Y}\mathcal{D})$ -familial.

The modifier “finitary” typically refers to a functor which preserves filtered colimits; that our usage agrees with this follows from Lemma 3.4 and the fact that a representable $\mathcal{P}\mathcal{C}(A, -): \mathcal{P}\mathcal{C} \rightarrow \mathbf{Set}$ is finitary just when A is in $\mathcal{F}\mathcal{C}$.

To see that finitary pointwise familial functors and transformations compose, we appeal to Proposition 3.11 and the following result:

Proposition 3.15. *The pointwise familial $F: \mathcal{P}\mathcal{C} \rightarrow \mathcal{P}\mathcal{D}$ is finitary if and only if it is $(\mathcal{F}\mathcal{C}, \mathcal{F}\mathcal{D})$ -familial; whence there is a 2-category $\mathbf{FAM}_{\text{pt}}^\omega$ of presheaf categories, finitary pointwise familial functors and pointwise familial transformations.*

Proof. For the non-trivial direction, let $t: B \rightarrow FA$ with $B \in \mathcal{F}\mathcal{D}$. On expressing B as a finite colimit of representables, the proof of Proposition 3.12 yields a cover of t by a linear operation $u: B \rightarrow FA$ obtained as a finite colimit in $\mathcal{B} \downarrow F$ of linear operations of the form $y_{d_I} \rightarrow FA_I$. By assumption, each A_I is in $\mathcal{F}\mathcal{C}$, whence $A = \text{colim}_I A_I$ is too. \square

3.4. Universal familial endofunctors. We now have all the ingredients we require for our first attempt at constructing a universal shapely monad \mathbf{U} on $\mathcal{P}\mathcal{C}$. As anticipated in the previous section, a naive attempt to construct it as a terminal object in the monoidal category $\mathbf{FAM}_{\text{pt}}(\mathcal{P}\mathcal{C}, \mathcal{P}\mathcal{C})$ fails for size reasons.

Proposition 3.16. *If $\mathcal{C} \neq 0$ and the category \mathcal{A} has a proper class of non-isomorphic objects, then $\mathbf{FAM}_{\text{pt}}(\mathcal{A}, \mathcal{P}\mathcal{C})$ has no terminal object; in particular, if $\mathcal{C} \neq 0$ then $\mathbf{FAM}_{\text{pt}}(\mathcal{P}\mathcal{C}, \mathcal{P}\mathcal{C})$ has no terminal object.*

Proof. By Proposition 3.8, it suffices to show that $\text{el}_{\mathcal{C}} \parallel \mathcal{A}$ has no terminal object. Suppose that (S, E) were terminal; fixing some $c \in \mathcal{C}$, we would then have for each $A \in \mathcal{A}$ a unique map

$$\begin{array}{ccc} \text{el } y_c & \xrightarrow{\text{el } t_A} & \text{el } S \\ & \searrow \Delta A & \swarrow E \\ & \mathcal{A} & \end{array} \quad \begin{array}{c} \varphi_A \\ \leftarrow \\ \leftarrow \\ \leftarrow \end{array}$$

where ΔA is the constant functor at A . Note that $t_A \in Sc$ satisfies $Et_A \cong A$; since there are a proper class of non-isomorphic A 's, there must be a proper class of distinct t_A 's, contradicting the fact that Sc is a set. \square

What permits the above negative argument is the fact that a pointwise familial functor may have linear operations of arbitrarily large input arity; this suggests restricting attention to the *finitary* pointwise familial functors whose linear input arities lie in the essentially small⁴ $\mathcal{F}\mathcal{C}$. We first note that:

Lemma 3.17. *Precomposition with the inclusion $J: \mathcal{F}\mathcal{C} \rightarrow \mathcal{P}\mathcal{C}$ induces an equivalence between the categories $\mathbf{FAM}_{\text{pt}}^\omega(\mathcal{P}\mathcal{C}, \mathcal{P}\mathcal{D})$ and $\mathbf{FAM}_{\text{pt}}(\mathcal{F}\mathcal{C}, \mathcal{P}\mathcal{D})$.*

Proof. Precomposing the equivalence $\mathbf{FAM}_{\text{pt}}(\mathcal{F}\mathcal{C}, \mathcal{P}\mathcal{D}) \rightarrow \text{el}_{\mathcal{D}} \parallel \mathcal{F}\mathcal{C}$ of Proposition 3.8 by $(-) \circ J: \mathbf{FAM}_{\text{pt}}^\omega(\mathcal{P}\mathcal{C}, \mathcal{P}\mathcal{D}) \rightarrow \mathbf{FAM}_{\text{pt}}(\mathcal{F}\mathcal{C}, \mathcal{P}\mathcal{D})$ evidently yields another equivalence; whence, by two-out-of-three, $(-) \circ J$ is an equivalence. \square

Unfortunately, even with the finitariness restriction we are still unable to construct a strictly terminal familial endofunctor:

Proposition 3.18. *If $\mathcal{C} \neq 0$ and \mathcal{A} is essentially small, then $\mathbf{FAM}_{\text{pt}}(\mathcal{A}, \mathcal{P}\mathcal{C})$ always has a weakly terminal object, but has a terminal object if and only if \mathcal{A} has no non-identity automorphisms; consequently, if $\mathcal{C} \neq 0$, then $\mathbf{FAM}_{\text{pt}}^\omega(\mathcal{P}\mathcal{C}, \mathcal{P}\mathcal{C})$ has a weakly terminal object, but not a terminal object.*

Proof. By Proposition 3.8 we may prove the stated properties for the equivalent category $\text{el}_{\mathcal{C}} \parallel \mathcal{A}$; but as $\mathcal{A} \simeq \mathcal{A}'$ with \mathcal{A}' small and now $\text{el}_{\mathcal{C}} \parallel \mathcal{A} \simeq \text{el}_{\mathcal{C}} \parallel \mathcal{A}'$, we may assume without loss of generality that \mathcal{A} is itself small. We construct a weakly terminal (S, E) in $\text{el}_{\mathcal{C}} \parallel \mathcal{A}$ as follows. The presheaf $S \in \mathcal{P}\mathcal{C}$ has:

$$Sc = \{ \text{functors } F: \mathcal{C}/c \rightarrow \mathcal{A} \} \quad \text{and} \quad S(f: d \rightarrow c): F \mapsto F(f \circ -),$$

while $E: \text{el } S \rightarrow \mathcal{A}$ is given by $E(F: \mathcal{C}/c \rightarrow \mathcal{A}) = F(1_c)$ on objects, and by:

$$f: F(f \circ -) \rightarrow F \quad \mapsto \quad F(f: f \rightarrow 1_c): Ff \rightarrow F1_c$$

on morphisms. To see weak terminality of (S, E) , consider some other (T, D) in $\text{el}_{\mathcal{C}} \parallel \mathcal{A}$. We define $p: T \rightarrow S$ in $\mathcal{P}\mathcal{C}$ by sending $t \in Tc$ to the element

$$p(t): \mathcal{C}/c = \text{el } y_c \xrightarrow{\text{el } t} \text{el } T \xrightarrow{D} \mathcal{A}$$

of Sc . Naturality of p in c follows because $\text{el}(t) \circ \text{el}(y_f) = \text{el}(t \circ y_f) = \text{el}(t \cdot f)$ for all $t \in T(c')$ and $f: c \rightarrow c'$ in \mathcal{C} . Furthermore, from the equality $p(t)(1_c) = Dt$, we deduce $E \circ \text{el } p = D: \text{el } T \rightarrow \mathcal{A}$ and so $(p, 1_D): (T, D) \rightarrow (S, E)$ in $\text{el}_{\mathcal{C}} \parallel \mathcal{A}$.

Now let \mathcal{A} have no non-identity automorphisms; replacing it by its (equivalent) skeleton, we may assume that in fact it has no non-identity isomorphisms, and so that each map (3.4) of $\text{el}_{\mathcal{C}} \parallel \mathcal{A}$ has φ an identity. In this case, we claim the weakly terminal (S, E) given above is terminal. Indeed, if $(q, 1_D): (T, D) \rightarrow (S, E)$ is any map in $\text{el}_{\mathcal{C}} \parallel \mathcal{A}$, then for each $t \in Tc$, the functor $q(t): \mathcal{C}/c \rightarrow \mathcal{A}$ satisfies $q(t)(1_c) = Dt = p(t)(1_c)$; but then $q(t)(h) = q(th)(1_d) = p(th)(1_d) = p(t)(h)$ for all $h: d \rightarrow c$, whence $q = p$ as required.

⁴A category is *essentially small* if it is equivalent to a small category.

Next let \mathcal{A} admit the non-identity automorphism $a \in \mathcal{A}(A, A)$, and assume that there is a terminal object (T, D) in $\text{el}_\varphi // \mathcal{A}$; we derive a contradiction. By terminality of (T, D) , there is for any $c \in \mathcal{C}$ a unique pair as on the left in

$$\begin{array}{ccc} \text{el } y_c & \xrightarrow{\text{el } p} & \text{el } T \\ \Delta A \searrow & \xleftarrow{\varphi} & \swarrow D \\ & \mathcal{A} & \end{array} \qquad \begin{array}{ccc} \text{el } y_c & \xrightarrow{\text{el } p} & \text{el } T \\ \Delta A \searrow & \xleftarrow{\varphi \cdot \Delta a} & \swarrow D \\ & \mathcal{A} & \end{array}$$

where here ΔA is the constant functor at A . But now the triangle on the right also describes a morphism $(y_c, \Delta A) \rightarrow (T, D)$; so we must have $\varphi \cdot \Delta a = \varphi$ and so, by invertibility of φ , that $\Delta a = \text{id}_{\Delta A}$, contradicting $a \neq \text{id}_A$.

For the final claim, note that we have $\mathbf{FAM}_{\text{pt}}^\omega(\mathcal{P}\mathcal{C}, \mathcal{P}\mathcal{C}) \simeq \mathbf{FAM}_{\text{pt}}(\mathcal{F}\mathcal{C}, \mathcal{P}\mathcal{C})$ by Lemma 3.17; now if $\mathcal{C} \neq 0$, then the essentially small $\mathcal{F}\mathcal{C}$ certainly contains non-identity automorphisms—for instance, the switch map $y_c + y_c \rightarrow y_c + y_c$ —and so $\mathbf{FAM}_{\text{pt}}^\omega(\mathcal{P}\mathcal{C}, \mathcal{P}\mathcal{C})$ has a weakly terminal object, but no terminal object. \square

4. ANALYTIC FUNCTORS AND SHAPELINESS

The underlying reason that there is no terminal object among finitary familial endofunctors of a presheaf category is that linear operations cannot be fixed by automorphisms of their input arities; this means that such automorphisms may be propagated up to the level of familial functors, so obstructing the existence of a terminal object. The next step in our pursuit of a universal shapely monad will attempt to resolve this problem by introducing *analytic* functors, whose generating operations can be fixed by input arity automorphisms.

4.1. Generic operations and analytic functors. The fundamental step in moving from familial to analytic functors is to generalise from linear to *generic* operations. In what follows, we write \mathfrak{S}_X for the automorphism group of any object $X \in \mathcal{C}$.

Definition 4.1. An object $X \in \mathcal{C}$ is *Galois* if for each $Y \in \mathcal{C}$, the composition action makes $\mathcal{C}(X, Y)$ into a connected \mathfrak{S}_X -set. An operation $t: B \rightarrow FA$ of a functor $F: \mathcal{A} \rightarrow \mathcal{B}$ is *generic* if it is Galois in its connected component of $B \downarrow F$.

(Our nomenclature draws on one of the basic examples of a Galois object: if $k \subset K$ is a Galois field extension, and \mathcal{A} is the category of intermediate field extensions, then K is Galois in \mathcal{A}^{op} .)

An object X is Galois when it admits a map to every other object (*weak initiality*) and, for any pair of maps $f, f': X \rightrightarrows Y$, there is an automorphism $\sigma \in \mathfrak{S}_X$ with $f' = f\sigma$ (*transitivity*); thus, Galois objects are initial “up to a group of automorphisms”. In these terms, a generic F -operation can be understood as one which, like a linear operation, consumes all of its input arity, but which may now be invariant under certain automorphisms of that arity.

The next result identifies our generic operations with those of [37, Definition 5.2], which when $\mathcal{A} = \mathcal{B} = \mathbf{Set}$ and $B = 1$ are equally those of [16].

Lemma 4.2. *An operation $t: B \rightarrow FA$ is generic if and only if for every square of the following form there exists some $\ell: A \rightarrow Y$ with $F\ell.t = u$ and $h\ell = k$:*

$$(4.1) \quad \begin{array}{ccc} B & \xrightarrow{u} & FY \\ t \downarrow & \nearrow F\ell & \downarrow Fh \\ FA & \xrightarrow{Fk} & FZ \end{array} .$$

Proof. We claim that X is Galois if and only if it is weakly initial and every diagram as in the solid part of

$$(4.2) \quad \begin{array}{ccc} & & Y \\ & \nearrow h & \downarrow g \\ X & \xrightarrow{f} & Z \end{array}$$

can be completed to a commuting diagram as displayed. Indeed, if X is Galois then in the situation of (4.2), weak initiality gives a map $k: X \rightarrow Y$, and transitivity gives some $\sigma \in \text{Aut}_X$ such that $f = gk\sigma$, so that we may take $h = k\sigma$. Conversely, if X satisfies the displayed condition, then taking $Y = Z = X$ and $f = 1_X$ shows that each $g \in \mathcal{C}(X, X)$ is split epimorphic; whence each $g \in \mathcal{C}(X, X)$ is invertible; whereupon taking $Y = X$ in (4.2) gives transitivity.

Now the condition on t above says that any cospan $t \rightarrow v \leftarrow u$ in $B \downarrow F$ can be completed to a commuting triangle, which thus says that t is Galois in its connected component, as desired. \square

Corollary 4.3. *Any map $h: u \rightarrow t$ in $B \downarrow F$ with generic codomain is a split epimorphism; in particular, any map between generic operations is an isomorphism.*

Proof. Take $k = 1_A$ in (4.1). \square

Replacing linear operations with generic ones in the definition of familial functor yields the notion of *analytic* functor.

Definition 4.4. A functor $F: \mathcal{A} \rightarrow \mathcal{B}$ is *analytic at stage* $B \in \mathcal{B}$ if each operation in $B \downarrow F$ is covered by a generic one; a transformation $\alpha: F \Rightarrow G$ is *analytic at stage* B if F and G are so, and the induced functor $B \downarrow F \rightarrow B \downarrow G$ preserves generic operations. We write simply *analytic* to mean ‘‘analytic at every stage’’.

Remark 4.5. Analytic endofunctors of **Set** and *weakly cartesian* transformations were introduced by Joyal in [16]; by [37, Theorems 10.10 & 10.11], they are precisely the filtered-colimit preserving analytic endofunctors and transformations of **Set** in our sense. However, as noted in the introduction, there are other possible ways to extend Joyal’s notion of analyticity to general presheaf categories; two which exist in the literature are the *quotient containers* of [1], and the *generalised species* of [8] (also studied in [7]). Neither of these generalisations are adequate for our purposes, since neither have familial functors as a special case.

Just as familial functors are obtained from coproducts of representables, so analytic functors arise from coproducts of *near-representables* in the sense of [34]:

Definition 4.6. Let $A \in \mathcal{A}$ and $G \leq \mathfrak{S}_A$. A *coinvariant* for G is a joint coequaliser $q: A \twoheadrightarrow A/G$ for the set of morphisms $\{\sigma: A \rightarrow A \mid \sigma \in G\}$; dually, an *invariant* for G is a joint equaliser $\iota: A \setminus^G \rightarrow A$ for the maps in G . A functor $F: \mathcal{A} \rightarrow \mathbf{Set}$ is *near-representable* if $F \cong \mathcal{A}(A, -)_{/G}$ for some $A \in \mathcal{A}$ and $G \leq \mathfrak{S}_A = \mathfrak{S}_{\mathcal{A}(A, -)}$.

Lemma 4.7. A functor $F: \mathcal{A} \rightarrow \mathcal{B}$ is analytic at stage $B \in \mathcal{B}$ if and only if the functor $\mathcal{B}(B, F-): \mathcal{A} \rightarrow \mathbf{Set}$ is a (possibly large) coproduct of near-representables.

Proof. This will follow as in Lemma 3.4 once we have proved that: $F \in [\mathcal{A}, \mathbf{Set}]$ is near-representable just when $\text{el } F$ contains a Galois object. For any (x, A) in $\text{el } F$, let $G = \mathfrak{S}_{(x, A)} \leq \mathfrak{S}_A$; now $x: y_A \rightarrow F$ coequalises $y_\sigma: y_A \rightarrow y_A$ for each $\sigma \in G$, and so descends to a map $\bar{x}: y_{A/G} \rightarrow F$. It suffices to show that \bar{x} is an isomorphism just when (x, A) is Galois. Surjectivity of \bar{x} corresponds to weak initiality of (x, A) ; injectivity requires that, for any $f, f': A \rightrightarrows B$ with $\bar{x}(f) = \bar{x}(f') = y$, we have $f' = f\sigma$ for some $\sigma \in G$, or in other words, that for any $f, f': (x, A) \rightrightarrows (y, B)$ in $\text{el } F$, there is some $\sigma: (x, A) \rightarrow (x, A)$ in G with $f' = f\sigma$: which is transitivity of (x, A) . \square

4.2. Pointwise analyticity. As before, when we consider endofunctors of presheaf categories, or more generally functors *into* a presheaf category, the most appropriate kind of analyticity is pointwise:

Definition 4.8. A functor $F: \mathcal{A} \rightarrow \mathcal{P}\mathcal{C}$ or transformation $\alpha: F \Rightarrow G: \mathcal{A} \rightarrow \mathcal{P}\mathcal{C}$ is *pointwise analytic* if it is analytic at all representable stages; F is called *small* if $y_c \downarrow F$ has a mere set of connected components for each $c \in \mathcal{C}$. We write $\mathbf{AN}_{\text{pt}}(\mathcal{A}, \mathcal{P}\mathcal{C})$ for the category of small pointwise analytic functors and pointwise analytic transformations.

In particular, by Lemma 4.7, a functor $F: \mathcal{A} \rightarrow \mathcal{P}\mathcal{C}$ is small pointwise analytic just when each $(F-)c$ is a small coproduct of near-representables; so, for example, comparing with the formula of Proposition 2.12, we find—as promised above—that the “free polycategory” endofunctor on the category of *symmetric* polygraphs is pointwise analytic, though it is not pointwise familial.

As in the familial case, a small pointwise analytic F is determined by the near-representable summands of each $(F-)c$ and how these transform under maps $(F-)f: (F-)d \rightarrow (F-)c$. We wish to give a representation of these data analogous to Definition 3.7; the new aspect is that, in encoding a near-representable summand $\mathcal{A}(A, -)_{/G}$, we must record not just the arity A but also the group G of automorphisms which fix it. We do this using the notion of *orbit category*.

Definition 4.9. The *orbit category* $\mathcal{O}(\mathcal{A})$ of a category \mathcal{A} has as objects, pairs (A, G) where $A \in \mathcal{A}$ and $G \leq \mathfrak{S}_A$, and as morphisms $[f]: (A, G) \rightarrow (B, H)$, equivalence classes of maps $f: A \rightarrow B$ in \mathcal{A} with the property that

$$(4.3) \quad \text{for all } \tau \in H, \text{ there exists } \sigma \in G \text{ with } \tau f = f\sigma,$$

where $[f] = [f']$ when there exists $\sigma \in G$ with $f' = f\sigma$. We write $J: \mathcal{A} \rightarrow \mathcal{O}(\mathcal{A})$ for the full embedding sending A to $(A, 1)$.

Intuitively, we regard the generating operations of $F \in \mathbf{AN}_{\text{pt}}(\mathcal{A}, \mathcal{P}\mathcal{C})$ as having input arities drawn not from \mathcal{A} but from $\mathcal{O}(\mathcal{A})$; we will make this precise by

equating such functors F with pointwise familial ones $F' \in \mathbf{FAM}_{\text{pt}}(\mathcal{O}(\mathcal{A}), \mathcal{P}\mathcal{C})$. First we describe the passage between functors with domains \mathcal{A} and $\mathcal{O}(\mathcal{A})$.

Proposition 4.10. $\mathcal{O}(\mathcal{A})$ admits all group invariants, and for any category \mathcal{B} admitting group invariants, composition with J induces an equivalence

$$(4.4) \quad \mathbf{INVAR}(\mathcal{O}(\mathcal{A}), \mathcal{B}) \xrightarrow{(-) \circ J} \mathbf{CAT}(\mathcal{A}, \mathcal{B})$$

with domain the category of invariant-preserving functors and transformations.

Proof. The statement says that $\mathcal{O}(\mathcal{A})$ is the free completion of \mathcal{A} under group invariants, and by [18, Theorem 5.35], this completion may be found as the full subcategory of $[\mathcal{A}, \mathbf{Set}]^{\text{op}}$ obtained by closing the representables under group invariants. So it suffices to identify $\mathcal{O}(\mathcal{A})$ with this full subcategory. Direct calculation using the Yoneda lemma shows that maps in $\mathcal{O}(\mathcal{A})$ from (A, G) to (B, H) are in bijection with maps $\mathcal{A}(B, -)_{/H} \rightarrow \mathcal{A}(A, -)_{/G}$ in $[\mathcal{A}, \mathbf{Set}]$; so there is a fully faithful $K: \mathcal{O}(\mathcal{A}) \rightarrow [\mathcal{A}, \mathbf{Set}]^{\text{op}}$ with $K(A, G) = \mathcal{A}(A, -)_{/G}$. By definition, each $\mathcal{A}(A, -)_{/G}$ in the image of K lies in the closure of the representables in $[\mathcal{A}, \mathbf{Set}]^{\text{op}}$ under group invariants, and so it suffices to show that this subcategory in fact has all group invariants—which is [34, Proposition 2.2]. \square

Explicitly, if \mathcal{B} admits group invariants and $H: \mathcal{A} \rightarrow \mathcal{B}$, then the invariant-preserving extension $H': \mathcal{O}(\mathcal{A}) \rightarrow \mathcal{B}$ is defined by $H'(A, G) = HA \setminus^{HG}$, where here $HG = \{H\sigma : \sigma \in G\} \leq \mathfrak{S}_{HA}$. In particular, if $F: \mathcal{A} \rightarrow \mathcal{B}$ is any functor between categories, then applying this construction to $JF: \mathcal{A} \rightarrow \mathcal{O}(\mathcal{B})$ yields an invariant-preserving $\mathcal{O}(F): \mathcal{O}(\mathcal{A}) \rightarrow \mathcal{O}(\mathcal{B})$ given by $\mathcal{O}(F)(A, G) = (FA, FG)$.

We will now show that, when $\mathcal{B} = \mathcal{P}\mathcal{C}$, the equivalence (4.4) restricts back to one between pointwise analytic functors out of \mathcal{A} and pointwise familial ones out of $\mathcal{O}(\mathcal{A})$. However, under this equivalence, pointwise analytic transformations correspond not to familial ones but to *near-familial* ones in the following sense:

Definition 4.11. A morphism $[f]: (A, G) \rightarrow (B, H)$ in $\mathcal{O}(\mathcal{A})$ is called *vertical* if the underlying map $f: A \rightarrow B$ is invertible in \mathcal{A} . For any $F': \mathcal{O}(\mathcal{A}) \rightarrow \mathcal{B}$, an operation t in $B \downarrow F'$ is called *near-linear* if it is covered by a linear operation via a map which is vertical in $\mathcal{O}(\mathcal{A})$. If $F, G: \mathcal{O}(\mathcal{A}) \rightarrow \mathcal{B}$ are familial at stage B , then a transformation $\alpha: F \Rightarrow G$ is *near-familial* at stage B if it preserves near-linear operations.

We now give our equivalence result, after a preparatory lemma: in the statement of the lemma, we call an object of an orbit category $\mathcal{O}(\mathcal{A})$ *near-initial* if it admits a vertical map from an initial object.

Lemma 4.12. (i) \mathcal{A} has a Galois object if and only if $\mathcal{O}(\mathcal{A})$ has an initial one. $F: \mathcal{A} \rightarrow \mathcal{B}$ preserves Galois objects if and only if $\mathcal{O}(F): \mathcal{O}(\mathcal{A}) \rightarrow \mathcal{O}(\mathcal{B})$ preserves near-initial objects.

(ii) Let \mathcal{B} admit group invariants and let $F: \mathcal{A} \rightarrow \mathcal{B}$ have invariant-preserving extension $F': \mathcal{O}(\mathcal{A}) \rightarrow \mathcal{B}$. We have $B \downarrow F' \cong \mathcal{O}(B \downarrow F)$ naturally in F .

Proof. For (i), $A \in \mathcal{A}$ is Galois just when each $\mathcal{A}(A, B)$ is a connected \mathfrak{S}_A -set, which is equivalent to the existence of a unique $[u_B]: (A, \mathfrak{S}_A) \rightarrow (B, 1)$ in $\mathcal{O}(\mathcal{A})$ for each $B \in \mathcal{A}$. Now, $[u_B]$ factors through each $[1]: (B, H) \rightarrow (B, 1)$, for, by

definition of a Galois object, any $h \in H$ yields an automorphism $g \in \mathfrak{S}_A$ such that $u_{BG} = hu_B$. So A is Galois just when (A, \mathfrak{S}_A) is initial in $\mathcal{O}(\mathcal{A})$. The second claim is immediate on observing that $(A, G) \in \mathcal{O}(\mathcal{A})$ is near-initial if and only if $(A, \mathfrak{S}_A) \in \mathcal{O}(\mathcal{A})$ is initial, if and only if $A \in \mathcal{A}$ is Galois.

For (ii), an object of $B \downarrow F'$ comprises $(A, G) \in \mathcal{O}(\mathcal{A})$ and $u: B \rightarrow FA \setminus^{FG}$ in \mathcal{B} . Now, to give u is equally to give a map $t: B \rightarrow FA$ satisfying $F\sigma.t = t$ for all $\sigma \in G$. This condition says that each $\sigma \in G$ lies in $\mathfrak{S}_t \leq \mathfrak{S}_A$, and so an object of $B \downarrow F'$ is equally a pair $(t \in \mathcal{B} \downarrow F, G \leq \mathfrak{S}_t)$. Arguing similarly on morphisms, we conclude that $B \downarrow F' \cong \mathcal{O}(B \downarrow F)$; naturality in F is straightforward. \square

Proposition 4.13. *Let \mathcal{B} admit group invariants. Under the equivalence (4.4), functors and transformations $\mathcal{A} \rightarrow \mathcal{B}$ which are analytic at stage B correspond to functors and transformations $\mathcal{O}(\mathcal{A}) \rightarrow \mathcal{B}$ which are familial, respectively near-familial at stage B . When $\mathcal{B} = \mathcal{P}\mathcal{C}$, the equivalence (4.4) restricts to one*

$$(4.5) \quad \mathbf{NFAM}_{\text{pt}}(\mathcal{O}(\mathcal{A}), \mathcal{P}\mathcal{C}) \xrightarrow{(-) \circ J} \mathbf{AN}_{\text{pt}}(\mathcal{A}, \mathcal{P}\mathcal{C})$$

with as domain the category of small pointwise familial functors and pointwise near-familial transformations $\mathcal{O}(\mathcal{A}) \rightarrow \mathcal{P}\mathcal{C}$.

Proof. Let $F: \mathcal{A} \rightarrow \mathcal{B}$ have invariant-preserving extension $F': \mathcal{O}(\mathcal{A}) \rightarrow \mathcal{B}$. Because any object (A, G) of $\mathcal{O}(\mathcal{A})$ admits a morphism to $(A, 1)$, and because all morphisms of $\mathcal{O}(\mathcal{A})$ have an underlying morphism in \mathcal{A} , $\mathcal{O}(-)$ preserves connected components. So, by Lemma 4.12, each $B \downarrow F$ is a coproduct of categories with Galois objects just when each $\mathcal{O}(B \downarrow F) \cong B \downarrow F'$ is a coproduct of categories with initial objects. Moreover, if $\alpha: F \Rightarrow G$ is a transformation between functors analytic at stage B , with invariant-preserving extension $\alpha': F' \Rightarrow G'$, then by Lemma 4.12, each functor $B \downarrow \alpha: B \downarrow F \rightarrow B \downarrow G$ preserves Galois objects just when each $\mathcal{O}(B \downarrow \alpha) \cong B \downarrow \alpha'$ preserves near-initial objects. This proves the first claim.

Now suppose that $\mathcal{B} = \mathcal{P}\mathcal{C}$. It is immediate that smallness is preserved under the preceding equivalences, and so the only additional point to verify is that $\mathbf{NFAM}_{\text{pt}}(\mathcal{O}(\mathcal{A}), \mathcal{P}\mathcal{C}) \subset \mathbf{INVAR}(\mathcal{O}(\mathcal{A}), \mathcal{P}\mathcal{C})$. But if $G: \mathcal{O}(\mathcal{A}) \rightarrow \mathcal{P}\mathcal{C}$ is pointwise familial, then each $(G-)c: \mathcal{O}(\mathcal{A}) \rightarrow \mathbf{Set}$, being a coproduct of representables, preserves connected limits and in particular group invariants; whence G preserves group invariants, as limits in $\mathcal{P}\mathcal{C}$ are pointwise. \square

Using this result, we may now give the promised analytic analogue of Definition 3.7, describing each small pointwise analytic $F: \mathcal{A} \rightarrow \mathcal{P}\mathcal{C}$ in terms of the near-representable summands of each $(F-)c$.

Definition 4.14. Let $F: \mathcal{A} \rightarrow \mathcal{P}\mathcal{C}$ be small pointwise analytic. The *spectrum* $S_F \in \mathcal{P}\mathcal{C}$ and *exponent* $E_F: \text{el } S_F \rightarrow \mathcal{O}(\mathcal{A})$ of F are the spectrum and exponent of the small pointwise familial $F': \mathcal{O}(\mathcal{A}) \rightarrow \mathcal{P}\mathcal{C}$ corresponding to F under (4.5).

Remark 4.15. Let us unpack this definition. Given $F \in \mathbf{AN}_{\text{pt}}(\mathcal{A}, \mathcal{P}\mathcal{C})$, we choose like before a generic operation in each connected component of $y_c \downarrow F$, and write \tilde{t} for the chosen generic cover of $t \in y_c \downarrow F$. The spectrum of F is now exactly as in Definition 3.7, while the exponent $E_F: \text{el } S_F \rightarrow \mathcal{O}(\mathcal{A})$ is given on objects by $E_F(t: y_c \rightarrow TA) = (A, \mathfrak{S}_t)$, where \mathfrak{S}_t is the automorphism group of

$t \in y_c \downarrow T$, or equally the set of all $\sigma \in \mathfrak{S}_A$ such that $(T\sigma)(t) = t$. To define E_F on a map $f: \widetilde{ty}_f \rightarrow t$ of $\text{el } S_F$, we form the square

$$\begin{array}{ccc} y_c & \xrightarrow{y_f} & y_d \\ t' = \widetilde{ty}_f \downarrow & & \downarrow t \\ FA' & \xrightarrow{Fu_f} & FA \end{array}$$

whose lower edge is *any* map induced by weak initiality of \widetilde{ty}_f in $y_c \downarrow F$, and take $E_F(f) = [u_f]: (A', \mathfrak{S}_{t'}) \rightarrow (A, \mathfrak{S}_t)$. Note that the mapping $f \mapsto u_f$ is only functorial “up to automorphism groups”, so that E_F may *not* exist as a functor $\text{el } S_F \rightarrow \mathcal{A}$.

Just as in the familial case, a small pointwise analytic $\mathcal{A} \rightarrow \mathcal{P}\mathcal{C}$ can be recovered from its spectrum and exponent. We express this in terms of an equivalence between $\mathbf{AN}_{\text{pt}}(\mathcal{A}, \mathcal{P}\mathcal{C})$ and the following category:

Definition 4.16. For any \mathcal{A} and small \mathcal{C} , the category $\text{el}_{\mathcal{C}} \parallel_v \mathcal{O}(\mathcal{A})$ has as objects, pairs $(S \in \mathcal{P}\mathcal{C}, E: \text{el } S \rightarrow \mathcal{O}(\mathcal{A}))$, and as maps $(S, E) \rightarrow (T, D)$, pairs of a presheaf map $p: S \rightarrow T$ and a pointwise vertical transformation φ of the form:

$$(4.6) \quad \begin{array}{ccc} \text{el } S & \xrightarrow{\text{el } p} & \text{el } T \\ & \searrow E \quad \varphi \quad \swarrow D & \\ & & \mathcal{O}(\mathcal{A}) . \end{array}$$

Proposition 4.17. *The assignment $F \mapsto (S_F, E_F)$ is the action on objects of an equivalence of categories between $\mathbf{AN}_{\text{pt}}(\mathcal{A}, \mathcal{P}\mathcal{C})$ and $\text{el}_{\mathcal{C}} \parallel_v \mathcal{O}(\mathcal{A})$.*

Proof. By Proposition 4.13, it suffices to show that $F' \mapsto (S_{F'}, E_{F'})$ underlies an equivalence of categories $\mathbf{NFAM}_{\text{pt}}(\mathcal{O}(\mathcal{A}), \mathcal{P}\mathcal{C}) \rightarrow \text{el}_{\mathcal{C}} \parallel_v \mathcal{O}(\mathcal{A})$. This is almost exactly as in Proposition 3.8, with the only difference arising on morphisms. By definition, a transformation $\alpha': F' \Rightarrow G'$ between pointwise familial functors $F', G': \mathcal{O}(\mathcal{A}) \rightarrow \mathcal{P}\mathcal{C}$ is near-familial just when each triangle as to the left of (3.5) has φ_t *vertical*, rather than invertible: this accounts for the differing 2-cell data between (3.4) and (4.6). \square

4.3. Universal analytic endofunctors. Now in seeking a universal shapely monad among analytic endofunctors, we must as before consider both composability and existence of a terminal object. This time we deal with terminality first. As in Proposition 3.16, there is a size obstruction to constructing a terminal object of the category $\mathbf{AN}_{\text{pt}}(\mathcal{P}\mathcal{C}, \mathcal{P}\mathcal{C})$, and so we must impose size restrictions.

Definition 4.18. If $\mathcal{A}' \subset \mathcal{A}$ and $\mathcal{B}' \subset \mathcal{B}$ are full replete subcategories, we say that $F: \mathcal{A} \rightarrow \mathcal{B}$ is $(\mathcal{A}', \mathcal{B}')$ -*analytic* if it is analytic at each $B \in \mathcal{B}'$, and each generic $t \in B \downarrow F$ has input arity in \mathcal{A}' . A transformation $\alpha: F \Rightarrow G$ between such functors is $(\mathcal{A}', \mathcal{B}')$ -*analytic* if it is analytic at every stage $B \in \mathcal{B}'$.

Definition 4.19. A pointwise analytic $F: \mathcal{P}\mathcal{C} \rightarrow \mathcal{P}\mathcal{D}$ is called *finitary* if it is $(\mathcal{F}\mathcal{C}, \mathcal{y}\mathcal{D})$ -analytic. We write $\mathbf{AN}_{\text{pt}}^{\omega}(\mathcal{P}\mathcal{C}, \mathcal{P}\mathcal{D})$ for the category of finitary pointwise analytic functors and pointwise analytic transformations.

This restriction is in fact enough: $\mathbf{AN}_{\text{pt}}^\omega(\mathcal{P}\mathcal{C}, \mathcal{P}\mathcal{C})$ —and more generally, $\mathbf{AN}_{\text{pt}}^\omega(\mathcal{P}\mathcal{D}, \mathcal{P}\mathcal{C})$ —*does* have a terminal object. To see this, we first argue as in Lemma 3.17 to establish an equivalence between $\mathbf{AN}_{\text{pt}}^\omega(\mathcal{P}\mathcal{D}, \mathcal{P}\mathcal{C})$ and $\mathbf{AN}_{\text{pt}}(\mathcal{F}\mathcal{D}, \mathcal{P}\mathcal{C})$; the claim will now follow once we show more generally that $\mathbf{AN}_{\text{pt}}(\mathcal{A}, \mathcal{P}\mathcal{C})$ has a terminal object whenever \mathcal{A} is essentially small. The key to proving this is the following lemma; in it we write $[\mathcal{I}, \mathcal{O}(\mathcal{A})]_v$ for the category of functors $\mathcal{I} \rightarrow \mathcal{O}(\mathcal{A})$ and pointwise vertical transformations, where \mathcal{I} is any small category.

Lemma 4.20. *Each connected component of $[\mathcal{I}, \mathcal{O}(\mathcal{A})]_v$ has an initial object.*

Proof. Let $(T, G): \mathcal{I} \rightarrow \mathcal{O}(\mathcal{A})$ be given on objects by $I \mapsto (TI, G_I)$ and on morphisms by $f \mapsto [Tf]: (TI, G_I) \rightarrow (TJ, G_J)$. Note that the family of subgroups $(G_I \leq \mathfrak{S}_{TI})_{I \in \mathcal{I}}$ satisfies the condition that

(\star) for all $f: I \rightarrow J$ and $\sigma \in G_J$, there exists $\tau \in G_I$ with $Tf \circ \tau = \sigma \circ Tf$.

Call a family of subgroups $H = (H_I \leq \mathfrak{S}_{TI})_{I \in \mathcal{I}}$ *suitable* if it satisfies (\star) with H_I and H_J in place of G_I and G_J . We claim that, if H^x is a suitable family of subgroups for each $x \in X$, then the family of subgroups $\bigvee_x H^x = (\bigvee_x H_I^x)_{I \in \mathcal{I}}$ is again suitable (here the join $\bigvee_x H_I^x$ is taken in the lattice of subgroups of \mathfrak{S}_{TI}). Indeed, if $f: I \rightarrow J$ in \mathcal{I} and $\sigma \in \bigvee_x H_J^x$, then $\sigma = \sigma_1 \cdots \sigma_n$ for some $\sigma_i \in H_J^{x_i}$; now by suitability of each H^{x_i} , there are elements $\tau_i \in H_I^{x_i}$ with $Tf \cdot \tau_i = \sigma_i \cdot Tf$ for each i , and so $\tau = \tau_1 \cdots \tau_n \in \bigvee_x H_I^x$ is an element with $Tf \cdot \tau = \sigma \cdot Tf$.

It follows that there is a largest suitable family of subgroups given by:

$$\tilde{G} = \bigvee \{H : H \text{ is a suitable family of subgroups}\} .$$

By suitability, $[Tf]: (TI, \tilde{G}_I) \rightarrow (TJ, \tilde{G}_J)$ is well-defined for each $f: I \rightarrow J$; as $G_I \leq \tilde{G}_I$, this assignation is functorial in f and so we obtain $(T, \tilde{G}): \mathcal{I} \rightarrow \mathcal{O}(\mathcal{A})$ and a vertical transformation $\xi: (T, \tilde{G}) \rightarrow (T, G)$ with components $\xi_I = [1_{TI}]$. We claim that (T, \tilde{G}) is in fact initial in its connected component.

First we show that any pair of vertical transformations $\alpha, \beta: (T, \tilde{G}) \rightrightarrows (S, H)$ are equal. Each component α_I or β_I is an equivalence class of maps $TI \rightarrow SI$, and so we may consider the family of subgroups

$$(K_I = \langle a^{-1}b \mid a \in \alpha_I, b \in \beta_I \rangle \leq \mathfrak{S}_{TI})_{I \in \mathcal{I}} .$$

We claim this family is suitable: for then $K_I \leq \tilde{G}_I$ so that $a^{-1}b \in \tilde{G}_I$ for all $a \in \alpha_I$ and $b \in \beta_I$, whence $\alpha_I = \beta_I$ as required. For suitability, it suffices to show that, if $(a, b) \in \alpha_J \times \beta_J$ and $f: I \rightarrow J$, then there exists $(c, d) \in \alpha_I \times \beta_I$ with $Tf \cdot c^{-1}d = a^{-1}b \cdot Tf$. For *any* $c \in \alpha_I$ we have by naturality of α that $[a \cdot Tf] = [Sf \cdot c]$; but then $a \cdot Tf = Sf \cdot (c\sigma)$ for some $\sigma \in \tilde{G}_I$, and so on replacing c by $c\sigma \in \alpha_I$ we may take it that in fact $a \cdot Tf = Sf \cdot c$. Similarly, we can find $d \in \beta_I$ such that $b \cdot Tf = Sf \cdot d$, and now $Tf \cdot c^{-1}d = a^{-1}b \cdot Tf$ as required.

To show initiality of (T, \tilde{G}) in its connected component, it now suffices to show that, for all cospans $\alpha: (T, \tilde{G}) \rightarrow (S, H) \leftarrow (R, K): \beta$ in $[\mathcal{I}, \mathcal{O}(\mathcal{A})]_v$ there is *some* map $\gamma: (T, \tilde{G}) \rightarrow (R, K)$. To this end, consider the family of subgroups

$$(L_I = \langle a^{-1}bc^{-1}d \mid a, d \in \alpha_I, b, c \in \beta_I \rangle \leq \mathfrak{S}_{TI})_{I \in \mathcal{I}} .$$

Repeating the above argument shows this family is suitable, and so $L_I \leq \tilde{G}_I$ for all $I \in \mathcal{I}$. Now, choosing any $a \in \alpha_I$ and $b \in \beta_I$, we have for each $I \in \mathcal{I}$ a well-defined map $\gamma_I = [b^{-1}a]: (TI, \tilde{G}_I) \rightarrow (RI, K_I)$. Indeed, if $\sigma \in K_I$ then $b\sigma \in \beta_I$ and so $\tau = a^{-1}b\sigma b^{-1}a \in L_I \leq \tilde{G}_I$ satisfies $b^{-1}a.\tau = \sigma b^{-1}a$ as required. Clearly $\beta_I.\gamma_I = \alpha_I$ for each I ; since each β_I is vertical, hence monic in $\mathcal{O}(\mathcal{A})$, we conclude by naturality of α that $\gamma: (T, \tilde{G}) \rightarrow (R, K)$ is also natural as required. \square

Using this, we are finally able to prove:

Proposition 4.21. *If \mathcal{A} is essentially small, then the category $\mathbf{AN}_{\text{pt}}(\mathcal{A}, \mathcal{P}\mathcal{C})$ has a terminal object; in particular, any $\mathbf{AN}_{\text{pt}}^\omega(\mathcal{P}\mathcal{D}, \mathcal{P}\mathcal{C})$ has a terminal object.*

Proof. It suffices by Proposition 4.17 to show that the equivalent category $\text{el}_{\mathcal{C}} \parallel_v \mathcal{O}(\mathcal{A})$ has a terminal object, and as before, we may assume without loss of generality that \mathcal{A} is in fact small. For any $c \in \mathcal{C}$, we know by Lemma 4.20 that each connected component of $[\mathcal{C}/c, \mathcal{O}(\mathcal{A})]_v$ has an initial object; make a choice of such, and for each $F \in [\mathcal{C}/c, \mathcal{O}(\mathcal{A})]_v$, write \tilde{F} for the chosen initial object in its connected component, and $u: \tilde{F} \rightarrow F$ for the unique vertical transformation. The required terminal $(S, E) \in \text{el}_{\mathcal{C}} \parallel_v \mathcal{O}(\mathcal{A})$ now has:

$$Sc = \{F \in [\mathcal{C}/c, \mathcal{O}(\mathcal{A})]_v : \tilde{F} = F\} \quad \text{and} \quad S(f: d \rightarrow c): F \mapsto \widetilde{F(f \circ -)},$$

and has $E: \text{el} S \rightarrow \mathcal{O}(\mathcal{A})$ given by $E(F, c) = F(1_c)$ on objects, and

$$f: (\widetilde{F(f \circ -)}, d) \rightarrow (F, c) \quad \mapsto \quad \widetilde{F(f \circ -)}(1_d) \xrightarrow{u_{1_d}} F(f \circ -)(1_d) = Ff \xrightarrow{Ff} F1_c$$

on morphisms. To see terminality of (S, E) , let (T, D) be another object of $\text{el}_{\mathcal{C}} \parallel_v \mathcal{O}(\mathcal{A})$. To define a map $f: T \rightarrow S$, we form for each $t \in Tc$ the composite

$$(4.7) \quad F_t: \mathcal{C}/c = \text{el} y_c \xrightarrow{\text{el} t} \text{el} T \xrightarrow{D} \mathcal{O}(\mathcal{A})$$

and now define $p(t) = \tilde{F}_t \in Sc$. For any $f: d \rightarrow c$, we have

$$p(t) \cdot f = \widetilde{\tilde{F}_t \circ \text{el} f} = \widetilde{F_t \circ \text{el} f} = \widetilde{F_t \cdot f} = p(t \cdot f),$$

so that p is natural in c . Moreover, we have a pointwise vertical transformation

$$\begin{array}{ccc} \text{el} T & \xrightarrow{\text{el} p} & \text{el} S \\ & \searrow \varphi & \swarrow E \\ & \mathcal{O}(\mathcal{A}) & \end{array}$$

whose component at $t \in Tc$ is the map $u_{1_c}: E(p(t)) = \tilde{F}_t(1_c) \rightarrow F_t(1_c) = Dt$. So we have a map $(p, \varphi): (T, D) \rightarrow (S, E)$ and to conclude the proof, we must show that any $(q, \psi): (T, D) \rightarrow (S, E)$ is equal to (p, φ) . For each $t \in Tc$, consider the composite functor

$$G_t: \mathcal{C}/c = \text{el} y_c \xrightarrow{\text{el} t} \text{el} T \xrightarrow{\text{el} q} \text{el} S \xrightarrow{E} \mathcal{O}(\mathcal{A}).$$

By naturality of q , this functor sends $f: d \rightarrow c$ to $q(t)(\widetilde{f \circ -})(1_d) \in \mathcal{O}(\mathcal{A})$, and there is now a vertical transformation $\xi: G_t \Rightarrow q(t): \mathcal{C}/c \rightarrow \mathcal{O}(\mathcal{A})$ with component

$$G_t(f) = q(t)(\widetilde{f \circ -})(1_d) \xrightarrow{u_{1_d}} q(t)(f \circ -)(1_d) = q(t)(f)$$

at $f: d \rightarrow c \in \mathcal{C}/c$. Since $q(t)$ is a (chosen) initial object in its connected component of $[\mathcal{C}/c, \mathcal{O}(\mathcal{A})]_v$, the map $\xi: G_t \Rightarrow q(t)$ must be a split epimorphism; since every map of $[\mathcal{C}/c, \mathcal{O}(\mathcal{A})]_v$ is (pointwise monomorphic and hence) monomorphic, ξ is thus invertible, so that $G_t \cong q(t)$. Since the composite vertical transformation

$$(4.8) \quad \begin{array}{ccc} \mathcal{C}/c & \xrightarrow{\text{el } qt} & \text{el } S \\ & \searrow \psi \cdot \text{el } t & \swarrow E \\ & \mathcal{O}(\mathcal{A}) & \\ & \nwarrow F_t = D \cdot \text{el } t & \end{array}$$

exhibits G_t (the upper composite) as connected to F_t in $[\mathcal{C}/c, \mathcal{O}(\mathcal{A})]_v$, this determines $q(t)$ uniquely as being $\tilde{F}_t = p(t)$; since this holds for all $t \in \text{el } T$, we conclude that $p = q$. Moreover, as $G_t \cong q(t)$ is initial in its connected component of $[\mathcal{C}/c, \mathcal{O}(\mathcal{A})]_v$, the 2-cell in (4.8) must be equal to $\varphi \cdot \text{el } t: G_t \Rightarrow F_t$; as this holds for all $t \in \text{el } T$, we have $\varphi = \psi$ as required. \square

Remark 4.22. For any small category \mathcal{C} , we may view the terminal object U of $\mathbf{AN}_{\text{pt}}^\omega(\mathcal{P}\mathcal{C}, \mathcal{P}\mathcal{C})$ as an object in $\mathbf{AN}_{\text{pt}}(\mathcal{P}\mathcal{C}, \mathcal{P}\mathcal{C})$. By Proposition 4.13 and by near-familiarity, any $F \in \mathbf{AN}_{\text{pt}}(\mathcal{P}\mathcal{C}, \mathcal{P}\mathcal{C})$ which admits a map to U must itself be finitary, so that the map $F \rightarrow U$ is unique if it exists. In other words, U is a *subterminal* object in $\mathbf{AN}_{\text{pt}}(\mathcal{P}\mathcal{C}, \mathcal{P}\mathcal{C})$; it follows that we can identify $\mathbf{AN}_{\text{pt}}^\omega(\mathcal{P}\mathcal{C}, \mathcal{P}\mathcal{C})$ with the slice category $\mathbf{AN}_{\text{pt}}(\mathcal{P}\mathcal{C}, \mathcal{P}\mathcal{C})/U$. We will revisit this point in Remark 6.3 below.

4.4. Composition of analytic functors. The passage from familial to analytic functors has thus fixed the problem we had previously, namely the lack of a terminal object among such functors. However, we are not in the clear yet, as we must still show that pointwise analytic functors compose. By modifying Lemma 3.9(i) to use Lemma 4.2 in place of Lemma 3.2 we may show that generic morphisms compose; now arguing as in Proposition 3.11 yields:

Proposition 4.23. *If $F: \mathcal{A} \rightarrow \mathcal{B}$ and $G: \mathcal{B} \rightarrow \mathcal{C}$ are $(\mathcal{A}', \mathcal{B}')$ - and $(\mathcal{B}', \mathcal{C}')$ -analytic, then their composite is $(\mathcal{A}', \mathcal{C}')$ -analytic, and has as generic operations at stage $C \in \mathcal{C}'$ precisely the composites $Gt.s: C \rightarrow GB \rightarrow GFA$ of G - and F -generic operations. The correspondingly analytic transformations between these functors are likewise composable; in particular, there is a 2-category \mathbf{AN} of categories, analytic functors and analytic transformations.*

However, this does not imply that pointwise analytic functors between presheaf categories are composable, since we do not know that pointwise analytic functors are necessarily analytic. In fact, this is not true, by virtue of:

Proposition 4.24. *Pointwise analytic functors between presheaf categories are not closed under composition.*

Proof. Consider the following two functors:

$$(4.9) \quad \begin{array}{ll} F: \mathbf{Set} \rightarrow \mathbf{Set}^2 & G: \mathbf{Set}^2 \rightarrow \mathbf{Set} \\ X \mapsto (X^2 \rightarrow X^2/\mathfrak{S}_2) & (A \rightarrow B) \mapsto A \times_B A . \end{array}$$

G is representable at $W = (2 \rightarrow 1)$, and so pointwise analytic; F is pointwise analytic with spectrum $1 \in \mathbf{Set}^2$ and exponent $\text{el } 1 = \mathbf{2} \rightarrow \mathcal{O}(\mathbf{Set})$ picking out the

arrow $(2, \mathfrak{S}_2) \rightarrow (2, 1)$. The composite $GF: \mathbf{Set} \rightarrow \mathbf{Set}$ sends a set X to

$$X^2 \times_{X^2/\mathfrak{S}_2} X^2 = \{(a, b, c, d) \in X^4 : (a, b) = (c, d) \text{ or } (a, b) = (d, c)\}.$$

Now, no operation $(a, a, a, a): 1 \rightarrow GF X$ can be generic, because the square left below has no filler $GF X \rightarrow GF\{0, 1\}$; while if $a \neq b \in X$, then no (a, b, a, b) or $(a, b, b, a): 1 \rightarrow GF X$ can be generic because the square below right has no filler in either direction.

$$\begin{array}{ccc} 1 & \xrightarrow{(0,1,0,1)} & GF\{0, 1\} \\ (a,a,a,a) \downarrow & & \downarrow GF! \\ GF X & \xrightarrow{GF!} & GF 1 \end{array} \qquad \begin{array}{ccc} 1 & \xrightarrow{(a,b,b,a)} & GF X \\ (a,b,a,b) \downarrow & & \downarrow GF! \\ GF X & \xrightarrow{GF!} & GF 1 \end{array}$$

So GF is not pointwise analytic, as there are no generic operations in $1 \downarrow GF$. \square

Corollary 4.25. $\mathbf{AN}_{\text{pt}}^\omega(\mathcal{P}\mathcal{C}, \mathcal{P}\mathcal{C})$ need not be monoidal under composition.

Proof. If F and G are as in the preceding proof, then $F\pi_1$ and ΔG lie in $\mathbf{AN}_{\text{pt}}^\omega(\mathbf{Set}^2, \mathbf{Set}^2)$. But if their composite $\Delta GF\pi_1$ were pointwise analytic, then so too would be $\pi_1(\Delta GF\pi_1)\Delta = GF$. \square

Remark 4.26. The preceding argument does not rule out the possibility that the composition-powers of the terminal finitary analytic endofunctor U of a presheaf category happen to be again analytic—which would allow for the construction of a monad structure on U . However, at least for the presheaf categories of our examples, the preceding argument may be adapted to show that this is not so.

5. CELLULAR FUNCTORS AND SHAPELINESS

We have now failed to construct a universal shapely monad on a presheaf category $\mathcal{P}\mathcal{C}$ in two different ways: there was no universal *familial* monad due to the lack of a terminal familial endofunctor, while there was no universal *analytic* monad due to the failure of pointwise analytic functors to be composition-closed.

Our next attempt to produce a universal shapely monad will focus on a special class of pointwise analytic functors, which we term *cellular*, that are closed under composition. This is achieved by way of an additional condition which allows their pointwise analyticity to be built up to analyticity at more complex stages, so that Proposition 4.23 can then be applied.

Building up this analyticity will require an analogue of Proposition 3.12, which showed that the stages of familiarity of a functor $\mathcal{A} \rightarrow \mathcal{B}$ are closed under colimits. The reason this does not carry over unchanged to the analytic setting is that the analogue of Lemma 3.9(ii) fails to hold, as the following explicit counterexample shows.

Proposition 5.1. *The generic operations of a functor $F: \mathcal{A} \rightarrow \mathcal{B}$ need not be closed under pointwise colimits in $\mathcal{B} \downarrow F$.*

Proof. Consider the pointwise analytic functor $F: \mathbf{Set} \rightarrow \mathbf{Set}^2$ from (4.9). By examination of its spectrum, this admits generic operations $t: y_0 \rightarrow F2$ and

$u: y_1 \rightarrow F2$ fitting into a span

$$\begin{array}{ccccc}
 & & y_0 & \longrightarrow & y_1 \\
 & \swarrow & \downarrow & & \downarrow \\
 & & t & & u \\
 y_1 & & \downarrow & & \\
 \downarrow & & F2 & \xlongequal{\quad} & F2 \\
 u & & \downarrow & & \\
 & & F2 & &
 \end{array}$$

in $\mathbf{Set}^2 \downarrow F$. We claim that the pushout $u +_t u: y_1 +_{y_0} y_1 \rightarrow F2$ of this span is not generic; in fact, we claim that there are no generic operations at all in $y_1 +_{y_0} y_1 \downarrow F$. Indeed, the functor G in (4.9) is representable at $y_1 +_{y_0} y_1$, and so $1 \downarrow GF \cong y_1 +_{y_0} y_1 \downarrow F$; but since by the proof of Proposition 4.24, the former category contains no generic operations, neither does the latter. \square

In light of this negative result, our first objective in this section will be to describe certain good colimit types under which generic operations *are* closed, and to show that for these colimit types, we do have an analogue of Proposition 3.12. We then introduce the notion of cellular functor, this being a pointwise analytic functor whose generic operations have input arities that can be constructed from representables using only these good colimit types. With this in place, it is then reasonably straightforward to show that cellular functors are closed under composition.

5.1. Arrow-genericity and arrow-analyticity. By the same argument as for linear operations, generic operations are closed under coproducts in $\mathcal{B} \downarrow F$, and at first this may appear to be all that we can salvage from Proposition 3.12 in the analytic case. But in fact, there is a class of morphisms in $\mathcal{B} \downarrow F$ along which generic operations are closed under pushout; we now introduce this class.

Definition 5.2. Let $F: \mathcal{A} \rightarrow \mathcal{B}$. We say that a map $(b, a): t_1 \rightarrow t_2$ in $\mathcal{B} \downarrow F$ as below is *arrow-generic* if t_1 and t_2 are generic for F and $(t_1, t_2): b \rightarrow F^2(a)$ is generic for the functor $F^2: \mathcal{A}^2 \rightarrow \mathcal{B}^2$.

$$(5.1) \quad \begin{array}{ccc}
 B_1 & \xrightarrow{b} & B_2 \\
 t_1 \downarrow & & \downarrow t_2 \\
 FA_1 & \xrightarrow{Fa} & FA_2
 \end{array}$$

Just as with linear and generic operations, there is a characterisation of arrow-genericity as a diagonal filling property:

Lemma 5.3. *Let t_1, t_2 be F -generic operations. A map $(b, a): t_1 \rightarrow t_2$ in $\mathcal{B} \downarrow F$ is arrow-generic just when for every commuting diagram as below (with $hj = ka$), there exists ℓ as shown with $h\ell = k$ and $F\ell.t_2 = u$ and $\ell a = j$.*

$$(5.2) \quad \begin{array}{ccccc}
 B_1 & \xrightarrow{b} & B_2 & \xrightarrow{u} & FY \\
 \downarrow t_1 & & \downarrow t_2 & \nearrow & \downarrow Fh \\
 & & & Fj & \\
 FA_1 & \xrightarrow{Fa} & FA_2 & \xrightarrow{Fk} & FZ \\
 & & & \nearrow & \\
 & & & F\ell &
 \end{array}$$

It follows that the class of arrow-generic maps in $\mathcal{B} \downarrow F$ contains the isomorphisms and is composition-closed.

Proof. First assume the condition in the statement. We must show that for any cube as below left, there are diagonal fillers $j_1: A_1 \rightarrow Y_1$ and $j_2: A_2 \rightarrow Y_2$ with $h_i j_i = k_i$ and $F j_i \cdot t_i = u_i$ and $j_2 a = y j_1$. Applying genericity of t_1 to the front face yields the required j_1 ; now the left and back faces give the solid part of a diagram as in (5.2) with the composite $y j_1$ as its diagonal, and applying the stated condition to this yields a filler j_2 for the back face satisfying the required equations.

$$\begin{array}{ccccc}
 & & B_2 & \xrightarrow{u_2} & FY_2 \\
 & \nearrow b & \downarrow u_1 & \nearrow Fy & \downarrow Fh_2 \\
 B_1 & \xrightarrow{\quad} & FY_1 & & \\
 \downarrow t_2 & & \downarrow & & \downarrow \\
 & \nearrow Fa & FA_2 & \xrightarrow{Fk_2} & FZ_2 \\
 & \downarrow t_1 & \downarrow Fk_1 & \nearrow Fz & \\
 FA_1 & \xrightarrow{\quad} & FZ_1 & &
 \end{array}
 \qquad
 \begin{array}{ccccc}
 & & B_2 & \xrightarrow{u} & FY \\
 & \nearrow b & \downarrow ub & \nearrow F1 & \downarrow Fh \\
 B_1 & \xrightarrow{\quad} & FY & & \\
 \downarrow t_2 & & \downarrow & & \downarrow \\
 & \nearrow Fa & FA_2 & \xrightarrow{Fk} & FZ \\
 & \downarrow t_1 & \downarrow Fj & \nearrow Fh & \\
 FA_1 & \xrightarrow{\quad} & FY & &
 \end{array}$$

Suppose conversely that $(b, a): t_1 \rightarrow t_2$ is arrow-generic. Given a diagram as in the solid part of (5.2), we apply arrow-genericity to the cube above right to obtain fillers for the front and back faces making everything commute. The front filler is necessarily j , and so the back filler is the $\ell: A_2 \rightarrow Y$ required for (5.2). \square

As mentioned above, the reason for introducing arrow-generic maps is that generic operations in $\mathcal{B} \downarrow F$ are closed under pushout along them; we show this in the next section, but first let us introduce the associated notion of analyticity.

Definition 5.4. A functor $F: \mathcal{A} \rightarrow \mathcal{B}$ is *arrow-analytic at stage* $b \in \mathcal{B}(B_1, B_2)$ if F is analytic at stages $B_1, B_2 \in \mathcal{B}$ and F^2 is analytic at stage $b \in \mathcal{B}^2$; we define arrow-analyticity of a transformation $\alpha: F \Rightarrow G$ correspondingly.

It should not yet be clear whether arrow-analyticity is a property that will be fulfilled in examples of interest. We will see that this is the case in Lemma 5.19 below, where we characterise arrow-generic morphisms $t_1 \rightarrow t_2$ in terms of an easily-satisfied relation between the automorphism groups of $t_1 \in B_1 \downarrow F$ and $t_2 \in B_2 \downarrow F$. Combining this with the following lemma will allow us to find many examples of arrow-analytic functors and transformations.

Lemma 5.5. *A functor $F: \mathcal{A} \rightarrow \mathcal{B}$ is arrow-analytic at $b \in \mathcal{B}(B_1, B_2)$ if and only if it is analytic at $B_1, B_2 \in \mathcal{B}$ and every $(b, a): t_1 \rightarrow t_2$ in $\mathcal{B} \downarrow F$ between generic operations is arrow-generic. A transformation $\alpha: F \Rightarrow G$ between two such functors is arrow-analytic at b if and only if it is analytic at $B_1, B_2 \in \mathcal{B}$.*

Proof. If F is analytic at stages $B_1, B_2 \in \mathcal{B}$, then every square as to the front of the diagram below left can be factorised through the back faces as displayed:

$$\begin{array}{ccc}
 & B_1 & \xrightarrow{b} & B_2 \\
 \tilde{t}_1 \swarrow & \downarrow & & \downarrow \tilde{t}_2 \\
 FA_1 & \xrightarrow{Fa} & FA_2 & \\
 Fu_1 \searrow & \downarrow t_1 & & \downarrow t_2 \\
 & FX_1 & \xrightarrow{Fx} & FX_2
 \end{array}
 \qquad
 \begin{array}{ccc}
 & B_1 & \xrightarrow{b} & B_2 \\
 s_1 \downarrow & & & \downarrow s_2 \\
 FY_1 & \xrightarrow{Fy} & FY_2 & .
 \end{array}$$

Here, $u_1: \tilde{t}_1 \rightarrow t_1$ and $u_2: \tilde{t}_2 \rightarrow t_2$ are generic covers obtained from analyticity at B_1 and B_2 , and a is induced by applying Lemma 4.2 to the generic \tilde{t}_1 . Now if the hypotheses in the statement hold, then $(\tilde{t}_1, \tilde{t}_2)$ is F^2 -generic and so each (t_1, t_2) in $b \downarrow F^2$ admits a generic cover, as required for F^2 to be analytic at b . Suppose conversely that F^2 is analytic at b , and consider a square as right above with generic sides; we must show that it is arrow-generic. So construct covers

$$(\tilde{t}_1, \tilde{t}_2) \xrightarrow{(u_1, u_2)} (t_1, t_2) \xrightarrow{(v_1, v_2)} (s_1, s_2)$$

in $b \downarrow F^2$, where (t_1, t_2) is an F^2 -generic cover, and where $(\tilde{t}_1, \tilde{t}_2)$ is obtained as above left using analyticity of F at B_1, B_2 . Since \tilde{t}_1 and s_1 are both F -generic operations at stage B_1 , $v_1 u_1$ is invertible by Corollary 4.3 and so u_1 is a split monomorphism; similarly u_2 is split monic. On the other hand, since (t_1, t_2) is F^2 -generic, the map (u_1, u_2) must—by Corollary 4.3 again—be a pointwise split epimorphism: whence u_1, u_2, v_1 and v_2 are invertible, so that (s_1, s_2) , like (t_1, t_2) , is arrow-generic as required. It follows that, if F is arrow-analytic at b , then the generic operations in $b \downarrow F^2$ are precisely the squares with generic sides; the statement about arrow-analytic transformations follows directly from this. \square

In the sequel, we will make use of this characterisation of arrow-analyticity without further comment. We conclude this section by recording the analogue of Definitions 3.10 and 4.18 for arrow-analytic functors:

Definition 5.6. If $\mathcal{I} \subset \mathcal{A}^2$ and $\mathcal{J} \subset \mathcal{B}^2$ are full replete subcategories, we say that $F: \mathcal{A} \rightarrow \mathcal{B}$ is $(\mathcal{I}, \mathcal{J})$ -arrow-analytic if it is arrow-analytic at each $b \in \mathcal{J}$, and each arrow-generic $(t_1, t_2) \in b \downarrow F^2$ as in (5.1) has its input arity a in \mathcal{I} . A transformation $\alpha: F \Rightarrow G$ between such functors is $(\mathcal{I}, \mathcal{J})$ -arrow-analytic if it is arrow-analytic at every stage $b \in \mathcal{J}$.

Proposition 5.7. If $F: \mathcal{A} \rightarrow \mathcal{B}$ and $G: \mathcal{B} \rightarrow \mathcal{C}$ are $(\mathcal{I}, \mathcal{J})$ - and $(\mathcal{J}, \mathcal{K})$ -arrow-analytic, then their composite is $(\mathcal{I}, \mathcal{K})$ -arrow-analytic, and correspondingly for the transformations between such functors.

Proof. Direct from the definitions and Proposition 4.23. \square

5.2. Building up stages of analyticity. We are now ready to see what the purpose of arrow-genericity and arrow-analyticity really is. We begin with a lemma which provides an analytic analogue of Lemma 3.9(ii) above.

Lemma 5.8. *Let $F: \mathcal{A} \rightarrow \mathcal{B}$ and consider a pointwise pushout square in $\mathcal{B} \downarrow F$ as below. If s_1, s_2 and t_1 are generic and (d, c) is arrow-generic, then t_2 is also generic and (b, a) is also arrow-generic.*

$$(5.3) \quad \begin{array}{ccc} s_1 & \xrightarrow{(g,f)} & t_1 \\ (d,c) \downarrow & & \downarrow (b,a) \\ s_2 & \xrightarrow{(m,n)} & t_2 \end{array}$$

Proof. We will show that every diagram as in the solid part of (5.2) admits a dashed filler; since t_1 is generic, this immediately implies that t_2 is generic, and so by Lemma 5.3 that (b, a) is arrow-generic. To prove the claim, observe that the stated filling condition can be described as a *left lifting property*: it says that, for each $h: Y \rightarrow Z$ in \mathcal{A} , each square in $\mathcal{B} \downarrow F$ as left below has a diagonal filler.

$$(5.4) \quad \begin{array}{ccc} t_1 & \xrightarrow{(ub,j)} & 1_{FY} \\ (b,a) \downarrow & \nearrow (u,\ell) & \downarrow (1,h) \\ t_2 & \xrightarrow{(u,k)} & Fh \end{array} \quad \begin{array}{ccc} s_1 & \xrightarrow{(ubg,jf)} & 1_{FY} \\ (d,c) \downarrow & \nearrow (um,\ell') & \downarrow (1,h) \\ s_2 & \xrightarrow{(um,kn)} & Fh \end{array}$$

Pasting the given square with the pushout (5.3) gives a square as right above; since (d, c) is arrow-generic, we induce a filler for this square as indicated and so by the universal property of pushout the required filler (u, ℓ) as left above. \square

In fact, we can do better than this: the characterisation of arrow-generic maps by a left lifting property allows us to show that they are also closed under *transfinite composition* [13, Definition 2.1.1]. As we do not need this further fact, we leave its verification to the interested reader.

We now use the preceding lemma to give the promised analytic analogue of Proposition 3.12; we reiterate that, in light of Proposition 5.1, the assumption of arrow-analyticity of b in part (ii) cannot be dropped.

Proposition 5.9. *Let \mathcal{A} be cocomplete and let $F: \mathcal{A} \rightarrow \mathcal{B}$.*

- (i) *If F is analytic at B , then it is arrow-analytic at 1_B ; if F is arrow-analytic at composable maps b and c , then it is also arrow-analytic at cb .*
- (ii) *For any pushout as below in \mathcal{B} , if F is analytic at B_1, B_2 and C_1 and arrow-analytic at b , then it is also analytic at C_2 and arrow-analytic at c .*

$$(5.5) \quad \begin{array}{ccc} B_1 & \xrightarrow{f_1} & C_1 \\ b \downarrow & & \downarrow c \\ B_2 & \xrightarrow{f_2} & C_2 \end{array}$$

The analogous results hold for natural transformations $\alpha: F \Rightarrow G: \mathcal{A} \rightarrow \mathcal{B}$.

Again, we could add an additional clause to this proposition showing closure of stages of arrow-analyticity under transfinite composition, but we refrain from doing so as we have no use for it in what follows.

Proof. Let F be analytic at B . Any map $(1_B, a): t_1 \rightarrow t_2$ between generic operations in $\mathcal{B} \downarrow F$ is a map in $B \downarrow F$, so that f is invertible by Corollary 4.3 and $(1_B, f)$ is arrow-generic by Lemma 5.3. This shows that B is arrow-analytic at 1_B by Lemma 5.5. Suppose next that F is arrow-analytic at $b: B_1 \rightarrow B_2$ and $c: B_2 \rightarrow B_3$. Given a square as below left with t_1 and t_3 generic, let $e: t_2 \rightarrow t_3c$ be a generic cover in $B_2 \downarrow F$ and let d be induced by genericity as centre below; this yields a factorisation of the left square as to the far right.

$$\begin{array}{ccccc}
B_1 & \xrightarrow{cb} & B_3 & & B_1 & \xrightarrow{t_2b} & FA_2 & & B_1 & \xrightarrow{b} & B_2 & \xrightarrow{c} & B_3 \\
t_1 \downarrow & & \downarrow t_3 & & t_1 \downarrow & \nearrow Fd & \downarrow Fe & & t_1 \downarrow & & t_2 \downarrow & & \downarrow t_3 \\
FA_1 & \xrightarrow{Fa} & FA_3 & & FA_1 & \xrightarrow{Fa} & FA_3 & & FA_1 & \xrightarrow{Fd} & FA_2 & \xrightarrow{Fe} & FA_3
\end{array}$$

By arrow-analyticity at b and c , both small squares are arrow-generic, whence also their composite by Lemma 5.3; this shows that B is arrow-analytic at cb as required for (i). Now suppose the hypotheses of (ii). We first show that F is analytic at C_2 . Let $z: C_2 \rightarrow FZ$, and consider the left cube in:

$$(5.6) \quad
\begin{array}{ccccc}
& & B_1 & \xrightarrow{f_1} & C_1 \\
& & \swarrow b & \downarrow f_2 & \swarrow c \\
B_2 & \xrightarrow{t_1} & C_2 & & \downarrow u_1 \\
\downarrow t_2 & & \downarrow t_1 & & \downarrow u_1 \\
FA_2 & \xrightarrow{Fa} & FA_1 & \xrightarrow{Fg_1} & FY_1 \\
& & \downarrow Fa & \downarrow z & \downarrow Fn \\
& & FA_2 & \xrightarrow{Fm} & FZ
\end{array}
\quad
\begin{array}{ccccc}
& & B_1 & \xrightarrow{f_1} & C_1 \\
& & \swarrow b & \downarrow f_2 & \swarrow c \\
B_2 & \xrightarrow{t_1} & C_2 & & \downarrow u_1 \\
\downarrow t_2 & & \downarrow t_1 & & \downarrow u_1 \\
FA_2 & \xrightarrow{Fa} & FA_1 & \xrightarrow{Fg_1} & FY_1 \\
& & \downarrow Fa & \downarrow z & \downarrow Fn \\
& & FA_2 & \xrightarrow{Fg_2} & FY_2
\end{array}$$

The front, left and right faces arise from generic covers $m: t_2 \rightarrow z f_2$, $a: t_1 \rightarrow t_2 b$ and $n: u_1 \rightarrow z c$, while the map g_1 across the back face is obtained as in (i) using genericity of t_1 . Since the top face is a pushout, and \mathcal{A} is cocomplete, the back and left faces admit a pushout in $\mathcal{B} \downarrow F$ which may be taken to be as right above. Since t_1 and t_2 are generic and F is arrow-analytic at b , the map $(b, a): t_1 \rightarrow t_2$ is arrow-generic; since u_1 is also generic, we conclude by Lemma 5.8 that u_2 is generic and $(c, y): u_1 \rightarrow u_2$ is arrow-generic.

Now taking $w: Y_2 \rightarrow Z$ to be the unique map with $wy = n$ and $wg_2 = m$, we see that $w: u_2 \rightarrow z$ provides a generic cover of z in $C_2 \downarrow F$, so that F is analytic at C_2 as required. For arrow-analyticity at c , suppose that $(c, n): u_1 \rightarrow z$ is a map between generic operations in $\mathcal{B} \downarrow F$. We may complete this to a cube as left above and form the generic pushout u_2 as to the right. Now since z is generic, the induced map $u_2 \rightarrow z$ in $C_2 \downarrow F$ is invertible by Corollary 4.3. So the left cube above is also a pushout; as $(b, a): t_1 \rightarrow t_2$ is arrow-generic, so too is $(c, n): u_1 \rightarrow z$ by Lemma 5.8. \square

5.3. Cellular analytic functors. By using Proposition 5.9, we can now build up the analyticity of a pointwise analytic functor between presheaf categories to analyticity at more complex stages by assuming suitable instances of arrow-analyticity. In order to specify what these more complex stages are, we borrow

some ideas from algebraic topology, in particular the theory of *cell complexes* in model categories; see [13, §2.1.2], for example.

Definition 5.10. Let I be a class of maps in a category \mathcal{C} with an initial object. A map $f: X \rightarrow Y$ is called a *finite relative I -complex* if either it is an isomorphism, or it can be written as a finite composite

$$(5.7) \quad X = X_0 \xrightarrow{f_1} X_1 \rightarrow \dots \xrightarrow{f_m} X_m = Y$$

where each f_i is a pushout of a map in I . An object $Y \in \mathcal{C}$ is called a *finite I -complex* if the unique map $0 \rightarrow Y$ is a finite relative I -complex. We write $\mathbf{Cx}(I) \subset \mathcal{C}$ for the full subcategory on the finite I -complexes, and $\mathbf{Cx}^2(I) \subset \mathcal{C}^2$ for the full subcategory on the relative finite I -complexes between finite I -complexes.

The modifier “finite” here comes from the fact that in (5.7) we allow only finite compositions; the general notion of cell complex in topology also allows for *transfinite* ones, and everything that follows could be adapted to this greater generality; however, like before, we refrain from giving this as we will not need it.

Definition 5.11. Let \mathcal{C} be a small category. A *bordage* on $\mathcal{P}\mathcal{C}$ is a filtered family $\emptyset = I_0 \subset I_1 \subset \dots \subset \bigcup_n I_n = I$ of maps in $\mathcal{P}\mathcal{C}$ such that:

- (i) Each $g \in I_{n+1}$ has representable codomain and domain a finite I_n -complex;
- (ii) Each representable object of $\mathcal{P}\mathcal{C}$ is a finite I -complex.

Note that condition (i) for a bordage ensures that each map in I has domain a finite I -complex and, as such, is an object of $\mathbf{Cx}^2(I)$; this is something which need not be true for a general class of maps I . Condition (ii) is much less important than (i) and will only play a role in Proposition 5.16 below.

Examples 5.12. (i) Any presheaf category $\mathcal{P}\mathcal{C}$ has a bordage given by $I = I_1 = \{0 \rightarrow y_c : c \in \mathcal{C}\}$. The finite I -complexes are the finite coproducts of representables, and the finite relative I -complexes are coproduct injections with complement a finite I -complex.

(ii) Let $\mathbf{2}$ be the arrow category $f: 0 \rightarrow 1$. The presheaf category $\mathcal{P}\mathbf{2}$ has a bordage given by $I_1 = \{0 \rightarrow y_0\}$ and $I \setminus I_1 = \{y_f: y_0 \rightarrow y_1\}$. The finite I -complexes are all finitely presentable presheaves, and the finite relative I -complexes are the monomorphisms with cofinite image.

(iii) Let \mathcal{G} be the category $s, t: 0 \rightrightarrows 1$. The presheaf category $\mathcal{P}\mathcal{G}$ has a bordage given by $I_1 = \{0 \rightarrow y_0\}$ and $I \setminus I_1 = \{\langle y_s, y_t \rangle: y_0 + y_0 \rightarrow y_1\}$, whose finite I -complexes and finite relative I -complexes are as in (ii).

(iv) Changing $I \setminus I_1$ in the preceding example to be $\{y_t: y_0 \rightarrow y_1\}$ yields another bordage on $\mathcal{P}\mathcal{G}$ whose finite I -complexes are now finite *forests* whose edges are all directed towards the roots. Changing $I \setminus I_1$ to be $\{y_s: y_0 \rightarrow y_1\}$ yields finite forests with edges directed away from the roots, while taking $I \setminus I_1$ to be $\{y_s, y_t\}$ yields finite forests whose edges may be oriented arbitrarily.

We will see further examples of bordages when we revisit the motivating examples of polycategories, properads and PROPs in Section 6 below.

Definition 5.13. Let I be a bordage on $\mathcal{P}\mathcal{C}$. A pointwise analytic $F: \mathcal{A} \rightarrow \mathcal{P}\mathcal{C}$ is I -cellular if any square as below with $b \in I$ and t_1, t_2 generic is arrow-generic.

$$(5.8) \quad \begin{array}{ccc} S & \xrightarrow{b} & y_c \\ t_1 \downarrow & & \downarrow t_2 \\ FA_1 & \xrightarrow{Fa} & FA_2 \end{array}$$

We will see in the following section that the cellularity condition is very easy to check in practice. Note that cellularity *almost* says that F is arrow-analytic at $b: S \rightarrow y_c$ for each $b \in I$, except that we do not assume that F is analytic at the domain object S . In fact, this is true by virtue of:

Proposition 5.14. *Let I be a bordage on $\mathcal{P}\mathcal{C}$ and let \mathcal{A} be a cocomplete category. Any I -cellular $F: \mathcal{A} \rightarrow \mathcal{P}\mathcal{C}$ is analytic at all $B \in \mathbf{Cx}(I)$ and arrow-analytic at all $b \in \mathbf{Cx}^2(I)$. The same holds for pointwise analytic transformations $\alpha: F \Rightarrow G$ between I -cellular functors.*

Proof. Let F be I -cellular. We prove by induction on n that F is analytic at every $B \in \mathbf{Cx}(I_n)$ and $b \in \mathbf{Cx}^2(I_n)$. For the base case $n = 0$, every $B \in \mathbf{Cx}(I_0)$ is initial: thus $B \downarrow F \cong \mathcal{A}$, and so as \mathcal{A} has an initial object, F is analytic at B . Since any $b \in \mathbf{Cx}^2(I_0)$ is invertible, F is analytic at b by Proposition 5.9.

Now assume the result for n . Each map $b: S \rightarrow y_c$ in I_{n+1} has domain in $\mathbf{Cx}(I_n)$, and so F is analytic at S ; thus I -cellularity implies that F is arrow-analytic at every $b \in I_{n+1}$. Applying Proposition 5.9 finitely many times shows that, if $f: X \rightarrow Y$ is a finite relative I_{n+1} -cell complex for which F is analytic at X , then F is also analytic at Y and arrow-analytic at f . Taking X to be initial and using the base case, shows that F is analytic at every $B \in \mathbf{Cx}(I_{n+1})$; while taking X to be an arbitrary finite I_{n+1} -complex shows that F is arrow-analytic at every $b \in \mathbf{Cx}^2(I_{n+1})$. The case of transformations is similar, and so omitted. \square

The preceding proposition shows us that the pointwise analyticity of functors $F: \mathcal{P}\mathcal{C} \rightarrow \mathcal{P}\mathcal{D}$ and $G: \mathcal{P}\mathcal{D} \rightarrow \mathcal{P}\mathcal{E}$ is stable under composition if there is a bordage I on $\mathcal{P}\mathcal{D}$ such that F is I -cellular and the input arities of G 's generic operations are I -cell complexes. However, GF need not then satisfy any cellularity conditions allowing it to compose further; the following definition ensures this.

Definition 5.15. Let I and J be bordages on $\mathcal{P}\mathcal{C}$ and $\mathcal{P}\mathcal{D}$. A pointwise analytic functor $F: \mathcal{P}\mathcal{C} \rightarrow \mathcal{P}\mathcal{D}$ is called (I, J) -cellular if every square (5.8) with $b \in J$ and t_1, t_2 generic is arrow-generic and has a a finite relative I -complex. We write $\mathbf{CELL}((\mathcal{C}, I), (\mathcal{D}, J))$ for the category of (I, J) -cellular functors and pointwise analytic transformations.

Proposition 5.16. *Let I and J be bordages on $\mathcal{P}\mathcal{C}$ and $\mathcal{P}\mathcal{D}$. A functor $F: \mathcal{P}\mathcal{C} \rightarrow \mathcal{P}\mathcal{D}$ is (I, J) -cellular if and only if it is $(\mathbf{Cx}^2(I), \mathbf{Cx}^2(J))$ -arrow-analytic. In particular, there is a 2-category \mathbf{CELL} of presheaf categories equipped with bordages, cellular analytic functors, and pointwise analytic transformations.*

Proof. By condition (ii) for a bordage, each representable in $\mathcal{P}\mathcal{D}$ is a finite J -complex, whence any $(\mathbf{Cx}^2(I), \mathbf{Cx}^2(J))$ -arrow-analytic functor is pointwise

analytic. By condition (i), we have $J \subset \mathbf{Cx}^2(J)$, and so any $(\mathbf{Cx}^2(I), \mathbf{Cx}^2(J))$ -arrow-analytic functor is (I, J) -cellular. This proves the “if” direction. For the “only if”, if F is (I, J) -cellular, then it is certainly J -cellular, and so arrow-analytic at each $b \in \mathbf{Cx}^2(J)$; it remains to show that each square (5.1) with $b \in \mathbf{Cx}^2(J)$ and t_1, t_2 generic has $a \in \mathbf{Cx}^2(I)$. Let K denote the collection of all arrows $b \in \mathbf{Cx}^2(J)$ for which each square (5.1) with t_1, t_2 generic has a a finite relative I -complex. By assumption $J \subset K$, and by examining the proof of Proposition 5.9 we see that K is stable under pushouts along maps into J -complexes and closed under composition, and so must comprise all of $\mathbf{Cx}^2(J)$. So each (5.1) with $b \in \mathbf{Cx}^2(J)$ and t_1, t_2 generic has a a relative finite I -complex, and it remains to show that the domain and codomain of a are in fact finite I -complexes. But whenever $B \in \mathbf{Cx}(J)$ and $t: B \rightarrow FA$ is generic, the following square has top edge in $\mathbf{Cx}^2(J)$ and generic sides:

$$\begin{array}{ccc} 0 & \xrightarrow{!} & B \\ !\downarrow & & \downarrow t \\ F0 & \xrightarrow{F!} & FA \end{array}$$

and so has bottom map a finite relative I -complex; whence $A \in \mathbf{Cx}(I)$ as required. The existence of the 2-category **CELL** now follows from this together with Proposition 5.7. \square

5.4. A combinatorial characterisation of arrow-genericity. We now know that cellular pointwise analytic functors are closed under composition; what we have not yet seen is that there *are* any cellular functors. In this section, we give a result which will allow us to verify that a given pointwise analytic functor is indeed cellular. The key concept required is that of a *minimal extension*.

Definition 5.17. Let $f: A \rightarrow B$ and let $\sigma \in \mathfrak{S}_A$. An *extension* of σ along f is some $\tau \in \mathfrak{S}_B$ for which $\tau f = f\sigma$. An extension is called *minimal* if whenever $g: B \rightarrow C$ satisfies $gf\sigma = gf$, also $g\tau = g$; equivalently, if $f, f\sigma: A \rightrightarrows B$ admit a coequaliser q , then τ is minimal just when $q\tau = q$.

The name is motivated by the case of $f: A \rightarrow B$ an injection in **Set**; for such an f , any $\sigma \in \mathfrak{S}_A$ has a unique minimal extension $\tau \in \mathfrak{S}_B$ with

$$(5.9) \quad \tau(x) = \begin{cases} \sigma(x) & \text{if } x \in \text{Im}(f); \\ x & \text{otherwise.} \end{cases}$$

So τ is minimal among extensions of σ in that it permutes the smallest possible part of B . This intuition works for monomorphisms in any presheaf category:

Proposition 5.18. *If $f: A \rightarrow B$ is monic in $\mathcal{P}\mathcal{C}$ then each $\sigma \in \mathfrak{S}_A$ admits at most one minimal extension along f ; this extension exists just when*

$$(5.10) \quad x \notin f(A) \text{ and } xh \in f(A) \quad \implies \quad xh \in f(A \setminus \sigma)$$

for all $x \in Bc$ and $h: d \rightarrow c$, and is then given componentwise as in (5.9).

Proof. If q coequalises f and $f\sigma$, then $\tau \in \mathfrak{S}_B$ is a minimal extension of σ just when $q\tau = \tau$, just when $q_c\tau_c = \tau_c$ for all c , just when each τ_c is a minimal extension of σ_c (as colimits in $\mathcal{P}\mathcal{C}$ are pointwise). So any minimal extension of σ must be given componentwise by (5.9), with (5.10) being just what is needed to ensure naturality of this definition in c . \square

We now use the notion of minimal extension to give a combinatorial characterisation of arrow-generic morphisms. As in Remark 4.15, we use \mathfrak{S}_{t_1} and \mathfrak{S}_{t_2} to denote the automorphism groups of $t_1 \in B_1 \downarrow F$ and $t_2 \in B_2 \downarrow F$.

Lemma 5.19. *Let \mathcal{A} have coequalisers and $F: \mathcal{A} \rightarrow \mathcal{B}$. A map $(b, a): t_1 \rightarrow t_2$ between generic operations in $\mathcal{B} \downarrow F$ is arrow-generic if and only if each $\sigma \in \mathfrak{S}_{t_1}$ admits a minimal extension $\tau \in \mathfrak{S}_{t_2}$ along $a: A_1 \rightarrow A_2$.*

Proof. We use the alternate characterisation of arrow-genericity of Lemma 5.3. For the “if” direction, suppose given a diagram as in the solid part of (5.2). As t_2 is generic, there exists a map $g: A_2 \rightarrow Y$ with $hg = k$ and $Fg.t_2 = u$; now both ga and j are maps $t_1 \rightarrow ub$ in $B_1 \downarrow F$ and so by genericity of t_1 there is some $\sigma \in \mathfrak{S}_{t_1}$ with $j = ga\sigma$. By the assumption on a , there is some minimal $\tau \in \mathfrak{S}_{t_2}$ with $\tau a = a\sigma$; letting $\ell = g\tau$, we have $\ell a = g\tau a = ga\sigma = j$ and $F\ell.t_2 = Fg.F\tau.t_2 = Fg.t_2 = u$. Now $ka\sigma = hga\sigma = hj = ka$, whence $k\tau = k$ by minimality of τ , and so $h\ell = hg\tau = k\tau = k$ as required for ℓ to be a filler.

For the “only if” direction, let $(b, a): t_1 \rightarrow t_2$ be arrow-generic and let $\sigma \in \mathfrak{S}_{t_1}$; we must find a minimal extension $\tau \in \mathfrak{S}_{t_2}$ along a . Let $q: A_2 \rightarrow Q$ be a coequaliser of a and $a\sigma$, and consider the diagram

$$\begin{array}{ccccc}
 B_1 & \xrightarrow{b} & B_2 & \xrightarrow{t_2} & FA_2 \\
 t_1 \downarrow & & \downarrow t_2 & \nearrow & \downarrow Fq \\
 & & F(a\sigma) & \nearrow & F\tau \\
 FA_1 & \xrightarrow{Fa} & FA_2 & \xrightarrow{Fq} & FQ .
 \end{array}$$

The solid part clearly commutes, and so we induce a map τ as displayed making everything commute. Since t_2 is generic, τ is invertible by Corollary 4.3; since $F\tau.t_2 = t_2$, we have $\tau \in \mathfrak{S}_{t_2}$. Moreover, $\tau a = a\sigma$, so τ is an extension of σ ; while $q\tau = q$ so that τ is minimal. \square

This result allows us to check in a concrete fashion the (I, J) -cellularity of a pointwise analytic $F: \mathcal{P}\mathcal{C} \rightarrow \mathcal{P}\mathcal{D}$. For this, it suffices to check (I, J_n) -cellularity for each n . This is trivial for $n = 0$ since $J_0 = \emptyset$; so suppose now that we have verified it up to n . To check (I, J_{n+1}) -cellularity, we must show that, for any $b: S \rightarrow y_d$ in $J_{n+1} \setminus J_n$, each square (5.1) with generic sides is arrow-generic with a a finite relative I -complex. We can do this using the previous result so long as we can compute all such squares (5.1).

Now, as F is (I, J_n) -cellular, it is by Proposition 5.14 analytic at the finite J_n -complex S . Thus, each square (5.1) is obtained from a generic $t_2: y_d \rightarrow FA_2$ —which we can classify by pointwise analyticity of F —upon forming a generic cover $a: t_1 \rightarrow t_2b$ in $S \downarrow F$, which can be calculated explicitly by applying the algorithm of Proposition 5.9 to some presentation of S as a finite J_n -complex.

Example 5.20. Let J be the bordage of Examples 5.12(ii) on $\mathcal{P}\mathbf{2}$, let I be any bordage on $\mathcal{P}\mathcal{C}$, and let $F: \mathcal{P}\mathcal{C} \rightarrow \mathcal{P}\mathbf{2}$ be pointwise analytic. Recalling that $J_1 = \{0 \rightarrow y_0\}$, the condition for F to be (I, J_1) -cellular is that, for each generic $t: y_0 \rightarrow FA$, the induced square

$$\begin{array}{ccc} 0 & \xrightarrow{!} & y_0 \\ \downarrow ! & & \downarrow t \\ F0 & \xrightarrow{Fa} & FA \end{array}$$

with generic sides is arrow-generic with a a finite relative I -complex. Arrow-genericity is trivial in this case, and so the condition is simply that A is a finite I -complex. Now, since $J_2 \setminus J_1 = \{y_f: y_0 \rightarrow y_1\}$, we see that F will be $(I, J_2) = (I, J)$ -cellular when, for each generic $t_2: y_0 \rightarrow FB$, the induced square

$$\begin{array}{ccc} y_0 & \xrightarrow{y_f} & y_1 \\ t_1 \downarrow & & \downarrow t_2 \\ FA & \xrightarrow{Fa} & FB \end{array}$$

with generic sides is arrow-generic and has a a finite relative J -complex. Let us see what this says relative to an explicit presentation of F as a pointwise coproduct of near-representables:

$$F = \sum_{u \in U} \mathcal{P}\mathcal{C}(B_u, -)_{/G_u} \xrightarrow{\alpha} \sum_{v \in V} \mathcal{P}\mathcal{C}(A_v, -)_{/H_v} .$$

Here, the map α is determined by a function $h: U \rightarrow V$ together with natural transformations $\alpha_u: \mathcal{P}\mathcal{C}(B_u, -)_{/G_u} \rightarrow \mathcal{P}\mathcal{C}(A_{hu}, -)_{/H_{hu}}$ —which, as in the proof of Proposition 4.10, correspond to maps $[a_u]: (A_{hu}, H_{hu}) \rightarrow (B_u, G_u)$ in $\mathcal{O}(\mathcal{P}\mathcal{C})$ (note that this is really just an explicit description of the exponent of F). In these terms, the necessary conditions for F to be (I, J) -cellular are that: each A_v should be a finite I -complex; each $a_u: A_{hu} \rightarrow B_u$ should be a finite relative I -complex; and each $\sigma \in H_{hu}$ should have a minimal extension $\tau \in G_u$ along a_u .

5.5. Universal cellular functors. We have now achieved what we set out to do in this section, by exhibiting a class of pointwise analytic functors which is closed under composition. Our broader objective, recall, is to construct a universal shapely monad as a terminal object among a suitable class of composable endofunctors; and so it remains to check the existence of a terminal object among cellular functors. Unfortunately, we have:

Proposition 5.21. $\text{CELL}((\mathcal{C}, I), (\mathcal{D}, J))$ need not admit a terminal object.

Proof. Let $\mathcal{C} = \mathcal{D} = \mathbf{2}$ and let both I and J be the bordage $\{0 \rightarrow y_0, y_0 \rightarrow y_1\}$ of Examples 5.12(ii). Consider the endofunctor $F: \mathcal{P}\mathbf{2} \rightarrow \mathcal{P}\mathbf{2}$ sending $f: A \rightarrow B$ to $f \times f: A \times A \rightarrow B \times B$; this is pointwise analytic, with explicit presentation

$$F = \mathcal{P}\mathbf{2}(y_1 + y_1, -)_{/1} \xrightarrow{\mathcal{P}\mathbf{2}(y_f + y_f, -)} \mathcal{P}\mathbf{2}(y_0 + y_0, -)_{/1} .$$

To see that F is (I, I) -cellular, we observe that $y_0 + y_0$ is a finite I -complex (= finitely presentable presheaf), that $y_f + y_f$ is a relative finite I -complex (=

monomorphism with cofinite image), and that the minimal extension condition is trivially satisfied: this verifies the three conditions of Example 5.20, as required.

In the terminology of Definition 4.14, F has spectrum $S_F = 1 \in \mathcal{P}\mathbf{2}$ —so that $\text{el } S_F \cong \mathbf{2}$ —and exponent $E_F: \mathbf{2} \rightarrow \mathcal{O}(\mathcal{P}\mathbf{2})$ picking out the arrow

$$[y_f + y_f]: (y_0 + y_0, 1) \rightarrow (y_1 + y_1, 1)$$

of $\mathcal{O}(\mathcal{P}\mathbf{2})$. It follows using Proposition 4.17 that for each $G \in \mathbf{AN}_{\text{pt}}(\mathcal{P}\mathbf{2}, \mathcal{P}\mathbf{2})$, pointwise analytic transformations $\alpha: F \Rightarrow G$ correspond bijectively with squares

$$(5.11) \quad \begin{array}{ccc} y_0 & \xrightarrow{y_f} & y_1 \\ t_1 \downarrow & & \downarrow t_2 \\ G(y_0 + y_0) & \xrightarrow{G(y_f + y_f)} & G(y_1 + y_1) \end{array}$$

in $\mathcal{P}\mathbf{2}$ with generic sides. We claim that whenever G is (I, I) -cellular, there are always two distinct such squares, so that G cannot be terminal in $\mathbf{CELL}((\mathbf{2}, I), (\mathbf{2}, I))$. Since G was arbitrary, this concludes the proof. Now, if G is (I, I) -cellular, then any square as displayed above must be arrow-generic; by Lemma 5.19, this means that each $\sigma \in \mathfrak{S}_{t_1}$ admits a minimal extension $\tau \in \mathfrak{S}_{t_2}$ along $y_f + y_f$. Using Proposition 5.18, we see that the switch isomorphism $\sigma_{12}: y_0 + y_0 \rightarrow y_0 + y_0$ has no minimal extension along $y_f + y_f$, and so we must have $\mathfrak{S}_{t_1} = 1$. Since $[y_f + y_f]: (y_0 + y_0, \mathfrak{S}_{t_1}) \rightarrow (y_1 + y_1, \mathfrak{S}_{t_2})$ in $\mathcal{O}(\mathcal{P}\mathbf{2})$, it follows that $\mathfrak{S}_{t_2} = 1$ too; whence the square

$$\begin{array}{ccc} y_0 & \xrightarrow{y_f} & y_1 \\ G\sigma_{12}.t_1 \downarrow & & \downarrow G\sigma_{12}.t_2 \\ G(y_0 + y_0) & \xrightarrow{G(y_f + y_f)} & G(y_1 + y_1) \end{array}$$

is a second, *distinct* instance of (5.11). This proves the claim. \square

6. SHAPELINESS IN CONTEXT

We have now failed for a third time to exhibit a notion of universal shapely monad: the imposition of cellularity, which fixed the failure of general analytic functors to compose, did so at the cost of destroying the terminal object existing among them. At this point, we prefer to leave for future work the problem of finding a general notion of shapeliness, and concentrate instead on giving a solution for the particular motivating examples from Section 2.

For these examples, the notion of cellularity turns out to be almost sufficient: some simple *ad hoc* additional conditions will be enough to obtain the desired universal shapely monad \mathbf{U} . With this in place, we can define a general shapely monad to be any pointwise analytic submonad of \mathbf{U} , and then provide an inductive construction of the free shapely monad on a generating set of operations. Finally, we apply this construction to our motivating examples, and thereby realise the main goal of this paper by exhibiting the monads for polycategories, properads and PROPs as free shapely monads on the basic wiring operations.

6.1. Universal shapely monads on (symmetric) polygraphs. Our first goal is to construct universal shapely monads on the presheaf categories of polygraphs and symmetric polygraphs from Section 2 which are suitable for analysing polycategories, properads and PROPs. We will find these universal monads among the class of cellular analytic endofunctors of the previous section; but in order to neutralise the counterargument of Proposition 5.21, we must further restrict the functors under consideration. We build on the observation that the monads in our examples act trivially on the set of objects of a (symmetric) polygraph.

Definition 6.1. An endofunctor F of either \mathcal{PP} or \mathcal{PP}_s is called *framed* if $FX(\star) \cong A \times X(\star)$ for some fixed set A .

Of course, “acting trivially” on objects is only the special case $A = 1$ of this definition. The reason for allowing the more general definition is to ensure that any pointwise analytic functor admitting a pointwise analytic transformation to a framed one is itself framed; see Remark 6.3 below.

Since framed functors are clearly stable under composition, we have for any bordage I on \mathcal{PP} or \mathcal{PP}_s a monoidal category of framed (I, I) -cellular endofunctors. In both the symmetric and non-symmetric cases, we are free to choose I in any way which ensures that the monads for polycategories, properads and PROPs are all in fact (I, I) -cellular; we now describe suitable such choices, and check by hand that corresponding monoidal categories of framed (I, I) -cellular endofunctors have a terminal object—so giving the desired universal shapely monads. Let us begin with the case of \mathcal{PP} . The bordage $I_{\mathbb{P}}$ we take has $(I_{\mathbb{P}})_1 = \{0 \rightarrow y_{\star}\}$ and $I_{\mathbb{P}} \setminus (I_{\mathbb{P}})_1$ the set of the following maps for all $n, m \in \mathbb{N}$:

$$\langle y_{\sigma_1}, \dots, y_{\sigma_n} \rangle: y_{\star} + \dots + y_{\star} \rightarrow y_{(n,m)} \quad \text{and} \quad \langle y_{\tau_1}, \dots, y_{\tau_m} \rangle: y_{\star} + \dots + y_{\star} \rightarrow y_{(n,m)} .$$

We now show that there is a universal framed $(I_{\mathbb{P}}, I_{\mathbb{P}})$ -cellular endofunctor. We make use of the sets $\mathcal{L}(n, m)$ of (n, m) -labelled finite polygraphs from Definition 2.6 above. We will call $X \in \mathcal{L}(n, m)$ *well-labelled* if the maps

$$\langle \ell_1^X, \dots, \ell_n^X \rangle: y_{\star} + \dots + y_{\star} \rightarrow |X| \quad \text{and} \quad \langle r_1^X, \dots, r_m^X \rangle: y_{\star} + \dots + y_{\star} \rightarrow |X|$$

are both relative finite $I_{\mathbb{P}}$ -complexes; and, extending the notation of Proposition 2.12, we write \mathfrak{S}_X for the set of label-preserving automorphisms of $|X|$.

Proposition 6.2. *The monoidal category of framed $(I_{\mathbb{P}}, I_{\mathbb{P}})$ -cellular endofunctors of \mathcal{PP} has a terminal object $U_{\mathbb{P}}$, which thus underlies a monad on \mathcal{PP} , the universal shapely monad. The spectrum $S \in \mathcal{PP}$ of $U_{\mathbb{P}}$ may be taken to be:*

$$S(\star) = \{u\} \quad \text{and} \quad S(n, m) = \{X \in \mathcal{L}(n, m) : X \text{ is well-labelled}\} ,$$

and the exponent $E: \text{el } S \rightarrow \mathcal{O}(\mathcal{PP})$ to have $E(u) = y_{\star}$ and

$$E(X) = (|X|, \mathfrak{S}_X), \quad E(\sigma_i: u \rightarrow X) = [\ell_i^X], \quad E(\tau_j: u \rightarrow X) = [r_j^X] .$$

Proof. By Proposition 4.17, we have $\mathbf{AN}_{\text{pt}}(\mathcal{PP}, \mathcal{PP}) \simeq \text{el}_{\mathbb{P}} //_{\nu} \mathcal{O}(\mathcal{PP})$; if we define $(\text{el}_{\mathbb{P}} //_{\nu} \mathcal{O}(\mathcal{PP}))' \subset \text{el}_{\mathbb{P}} //_{\nu} \mathcal{O}(\mathcal{PP})$ to be the full subcategory corresponding under this equivalence to the full subcategory of framed $(I_{\mathbb{P}}, I_{\mathbb{P}})$ -cellular endofunctors, then it suffices to show that (S, E) as defined above is terminal in this category.

First, let us call a functor $\mathbf{P}/\star \cong 1 \rightarrow \mathcal{O}(\mathcal{P}\mathbf{P})$ *acceptable* if it picks out the object $(y_\star, 1)$, and a functor $\mathbf{P}/(n, m) \rightarrow \mathcal{O}(\mathcal{P}\mathbf{P})$ *acceptable* if it takes the form

$$(6.1) \quad \begin{array}{ccc} \sigma_1 \cdots \sigma_n & & \tau_1 \cdots \tau_m \\ & \searrow \sigma_1 \quad \swarrow \sigma_n & \\ & \text{id}_{(n,m)} & \\ & \swarrow \tau_1 \quad \searrow \tau_m & \\ & & \end{array} \mapsto \begin{array}{ccc} (y_\star, 1) \cdots (y_\star, 1) & & (y_\star, 1) \cdots (y_\star, 1) \\ & \searrow [\ell_1] \quad \swarrow [\ell_n] & \\ & (X, G) & \\ & \swarrow [r_1] \quad \searrow [r_m] & \end{array}$$

with (X, ℓ, r) a well-labelled polygraph. By an argument like Example 5.20 above, a pointwise analytic $F: \mathcal{P}\mathbf{P} \rightarrow \mathcal{P}\mathbf{P}$ is framed $(I_{\mathbf{P}}, I_{\mathbf{P}})$ -cellular just when, for each element $t \in S_F(x)$ of its spectrum, the composite

$$F_t: \mathbf{P}/x = \text{el } y_x \xrightarrow{\text{el } t} \text{el } S_F \xrightarrow{E_F} \mathcal{O}(\mathcal{P}\mathbf{P})$$

is acceptable. Noting that this F_t is the same as (4.7) appearing in the proof of Proposition 4.21, we thus continue by emulating the rest of that proof.

Recall the key Lemma 4.20 stating that, for each $x \in \mathbf{P}$, the connected component of any $F \in [\mathbf{P}/x, \mathcal{O}(\mathcal{P}\mathbf{P})]_v$ contains an initial object \tilde{F} . We claim that, if F is acceptable, then so too is \tilde{F} . This is trivial when $x = \star$, while if $x = (n, m)$, then \tilde{F} is obtained from F as in (6.1) simply by changing its value at $\text{id}_{(n,m)}$ from (X, G) to (X, \mathfrak{S}_X) . So the analogue of Lemma 4.20 holds for acceptable functors; it follows that we can define a terminal object (S', E') for $(\text{el } \mathbf{P} //_{\mathbf{v}} \mathcal{O}(\mathcal{P}\mathbf{P}))'$ by taking

$$(6.2) \quad S'(x) = \{ F \in [\mathbf{P}/x, \mathcal{O}(\mathcal{P}\mathbf{P})]_v : \tilde{F} = F \text{ is acceptable} \},$$

with the remaining data defined exactly as in Proposition 4.21 above. All that remains is to identify this (S', E') with the (S, E) in the statement. Once again, this is trivial at stage \star , while at stage (n, m) , any acceptable F by definition has the form (6.1); but the further requirement that $F = \tilde{F}$ means that $G = \mathfrak{S}_X$, so that F determines and is determined by the well-labelled polygraph (X, ℓ, r) . \square

Remark 6.3. As in Remark 4.22, if we view the terminal framed cellular endofunctor of $\mathcal{P}\mathbf{P}$ as an object $U \in \mathbf{AN}_{\text{pt}}(\mathcal{P}\mathbf{P}, \mathcal{P}\mathbf{P})$, then any pointwise analytic F which admits a map to U in this category must itself be framed $(I_{\mathbf{P}}, I_{\mathbf{P}})$ -cellular. So U is subterminal in $\mathbf{AN}_{\text{pt}}(\mathcal{P}\mathbf{P}, \mathcal{P}\mathbf{P})$, and the slice category $\mathbf{AN}_{\text{pt}}(\mathcal{P}\mathbf{P}, \mathcal{P}\mathbf{P})/U$ may be identified with the monoidal category of framed $(I_{\mathbf{P}}, I_{\mathbf{P}})$ -cellular endofunctors.

The case of the presheaf category $\mathcal{P}\mathbf{P}_s$ of symmetric polygraphs is very similar: the maps in the bordage $I_{\mathbf{P}_s}$ are identical in form to those of $I_{\mathbf{P}}$ —though now living on a different category—and we now obtain:

Proposition 6.4. *The monoidal category of framed $(I_{\mathbf{P}_s}, I_{\mathbf{P}_s})$ -cellular endofunctors of $\mathcal{P}\mathbf{P}_s$ has a terminal object $U_{\mathbf{P}_s}$, which thus underlies a monad on $\mathcal{P}\mathbf{P}_s$, the universal shapely monad. The spectrum $S \in \mathcal{P}\mathbf{P}_s$ of $U_{\mathbf{P}_s}$ may be taken to be:*

$$S(\star) = \{u\} \quad \text{and} \quad S(n, m) = \{X \in \mathcal{L}_s(n, m) : X \text{ is well-labelled}\},$$

with symmetric actions on $S(n, m)$ given by $X \mapsto \psi \cdot X \cdot \varphi$ as in Definition 2.6(c); the exponent $E: \text{el } S \rightarrow \mathcal{O}(\mathcal{P}\mathbf{P}_s)$ now has $E(u) = y_\star$, $E(X) = (|X|, \mathfrak{S}_X)$ and

$$E(\sigma_i: u \rightarrow X) = [\ell_i^X], \quad E(\tau_j: u \rightarrow X) = [r_j^X], \quad E(\xi_{\varphi, \psi}: \psi \cdot X \cdot \varphi \rightarrow X) = [1_{|X|}].$$

6.2. Free shapely monads. Now that we have universal shapely monads on the presheaf categories of polygraphs and symmetric polygraphs, we are finally in a position to define more general shapely monads. It will be convenient to abstract away from the particularities of our examples as follows.

Definition 6.5. Let $U \in \mathbf{AN}_{\text{pt}}(\mathcal{P}\mathcal{C}, \mathcal{P}\mathcal{C})$ be subterminal. We write \mathbf{AN}_U for the full subcategory of $\mathbf{AN}_{\text{pt}}(\mathcal{P}\mathcal{C}, \mathcal{P}\mathcal{C})$ on the U -analytic endofunctors: those admitting a map to U . We call U nice if \mathbf{AN}_U is closed in $\mathbf{CAT}(\mathcal{P}\mathcal{C}, \mathcal{P}\mathcal{C})$ under the composition monoidal structure, and in this case we write \mathbf{MND}_U for the category of U -analytic monads: monoids in \mathbf{AN}_U .

Clearly, the subterminal U in $\mathbf{AN}_{\text{pt}}(\mathcal{P}\mathcal{C}, \mathcal{P}\mathcal{C})$ becomes terminal in \mathbf{AN}_U ; when U is nice, this terminal object has a unique monoid structure making it into a terminal object \mathbf{U} in \mathbf{MND}_U . The universal shapely monads of Propositions 6.2 and 6.4 arise in this way from the nice subterminal objects $U_{\mathbb{P}}$ and $U_{\mathbb{P}_s}$ in the categories of pointwise analytic endofunctors of $\mathcal{P}\mathbb{P}$ and $\mathcal{P}\mathbb{P}_s$; here “ $U_{\mathbb{P}}$ -analytic” means “framed $(I_{\mathbb{P}}, I_{\mathbb{P}})$ -cellular” and likewise for \mathbb{P}_s .

Definition 6.6. Let $U \in \mathbf{AN}_{\text{pt}}(\mathcal{P}\mathcal{C}, \mathcal{P}\mathcal{C})$ be subterminal. A U -analytic endofunctor F is *shapely* if the unique pointwise analytic $F \rightarrow U$ is pointwise monic. If U is nice, then a U -analytic monad is called *shapely* if its underlying endofunctor is so. We write $\mathbf{SH}_U \subset \mathbf{AN}_U$ and $\mathbf{SHM}_U \subset \mathbf{MND}_U$ for the full subcategories on the shapely endofunctors and monads.

By the *free shapely monad* on a shapely endofunctor F , we mean the value at F of a left adjoint to the forgetful functor $\mathbf{SHM}_U \rightarrow \mathbf{SH}_U$. To construct free shapely monads we will first need to analyse more closely the structure of shapely endofunctors. The following two results are the key to doing so.

Proposition 6.7. *For any \mathcal{A} and \mathcal{C} (with \mathcal{C} small), the category $\mathbf{AN}_{\text{pt}}(\mathcal{A}, \mathcal{P}\mathcal{C})$ admits a factorisation system (pointwise epi, pointwise mono).*

Here, and subsequently, the term “factorisation system” refers to an orthogonal factorisation system in the sense of Freyd–Kelly[10].

Proof. First we show that pointwise epimorphic and pointwise monomorphic transformations are orthogonal in $\mathbf{AN}_{\text{pt}}(\mathcal{A}, \mathcal{P}\mathcal{C})$: this says that any square

$$\begin{array}{ccc} F & \xrightarrow{\alpha} & G \\ \gamma \downarrow & \varepsilon \swarrow & \downarrow \delta \\ H & \xrightarrow{\beta} & K \end{array}$$

in $\mathbf{AN}_{\text{pt}}(\mathcal{A}, \mathcal{P}\mathcal{C})$ with α pointwise epimorphic and β pointwise monomorphic admits a unique diagonal filler ε as displayed. As pointwise epimorphic and monomorphic transformations are orthogonal in $\mathbf{CAT}(\mathcal{A}, \mathcal{P}\mathcal{C})$, there is certainly a unique transformation $\varepsilon: G \Rightarrow H$; we must show it is pointwise analytic. For each $c \in \mathcal{C}$ we have the factorisation

$$y_c \downarrow \delta \quad = \quad y_c \downarrow G \xrightarrow{y_c \downarrow \varepsilon} y_c \downarrow H \xrightarrow{y_c \downarrow \beta} y_c \downarrow K .$$

Now since β is pointwise monomorphic, $y_c \downarrow \beta$ is fully faithful and so reflects generic operations; since $y_c \downarrow \delta$ preserves them, we conclude that $y_c \downarrow \varepsilon$ preserves generics, whence ε is pointwise analytic as required.

It remains to show that any $\delta: G \Rightarrow K$ in $\mathbf{AN}_{\text{pt}}(\mathcal{P}\mathcal{C}, \mathcal{P}\mathcal{C})$ has a pointwise (epi, mono) factorisation. Let $\delta = \beta\varepsilon: G \Rightarrow H \Rightarrow K$ be such a factorisation in $\mathbf{CAT}(\mathcal{A}, \mathcal{P}\mathcal{C})$; we must show that H , β and ε are pointwise analytic. We argue as before to see that each $y_c \downarrow \varepsilon$ preserves generics, but since ε is pointwise epimorphic, $y_c \downarrow \varepsilon$ is also surjective on objects; whence each $t \in y_c \downarrow H$ has a generic cover obtained by lifting along $y_c \downarrow \varepsilon$, taking a generic cover there, and then applying the generic-preserving $y_c \downarrow \varepsilon$. This shows that H and ε are pointwise analytic. Moreover, as genericity is stable under isomorphism, each generic operation in $y_c \downarrow H$ is the image of a generic operation in $y_c \downarrow G$. Since $y_c \downarrow \delta$ preserves generics, so does $y_c \downarrow \beta$, and so β is also pointwise analytic. \square

Proposition 6.8. *The (pointwise epi, pointwise mono) factorisation system on $\mathbf{AN}_{\text{pt}}(\mathcal{A}, \mathcal{P}\mathcal{C})$ corresponds under Proposition 4.17 to the factorisation system $(\mathcal{E}, \mathcal{M})$ on $\text{el}_{\mathcal{E}} \parallel_v \mathcal{O}(\mathcal{A})$ for which \mathcal{E} and \mathcal{M} comprise those maps (p, φ) as in (4.6) for which p is epimorphic, respectively p is monic and φ is invertible.*

Proof. We begin by showing that $(\mathcal{E}, \mathcal{M})$ is a factorisation system on $\text{el}_{\mathcal{E}} \parallel_v \mathcal{O}(\mathcal{A})$. First, any map $(p, \varphi): (S, E) \rightarrow (T, D)$ therein admits the $(\mathcal{E}, \mathcal{M})$ -factorisation

$$(S, E) \xrightarrow{(e, \varphi)} (R, E. \text{el } m) \xrightarrow{(m, 1)} (T, D)$$

where $p = me: S \rightarrow R \rightarrow T$ is a (pointwise epi, pointwise mono) factorisation in $\mathcal{P}\mathcal{C}$. It remains to show that any square

$$\begin{array}{ccc} (S, E) & \xrightarrow{(f, \varphi)} & (T, D) \\ (h, \theta) \downarrow & \swarrow (j, \delta) & \downarrow (k, \kappa) \\ (V, C) & \xrightarrow{(g, \gamma)} & (W, B) \end{array}$$

with f epimorphic, g monomorphic, and γ invertible, admits a unique diagonal filler (j, δ) as indicated. By the orthogonality of epimorphic and monomorphic maps in $\mathcal{P}\mathcal{C}$, there is a unique $j: T \rightarrow V$ such that $jf = h$ and $gj = k$. But as γ is invertible, the unique δ making the lower triangle commute is given by $\kappa \circ (\gamma^{-1} \text{el } j)$; a short calculation shows that the top triangle then also commutes.

So $(\mathcal{E}, \mathcal{M})$ is a factorisation system, and to complete the proof, it suffices to show that under the equivalence $\mathbf{AN}_{\text{pt}}(\mathcal{A}, \mathcal{P}\mathcal{C}) \rightarrow \text{el}_{\mathcal{E}} \parallel_v \mathcal{O}(\mathcal{A})$ of Proposition 4.17, pointwise epimorphic maps correspond to maps in \mathcal{E} ; it then follows by orthogonality that pointwise monomorphic maps correspond to ones in \mathcal{M} . Now, $\alpha: F \Rightarrow G$ in $\mathbf{AN}_{\text{pt}}(\mathcal{A}, \mathcal{P}\mathcal{C})$ is pointwise epimorphic just when each functor

$$(6.3) \quad y_c \downarrow \alpha: y_c \downarrow F \rightarrow y_c \downarrow G$$

is surjective on objects. On the other hand, the c -component of the induced transformation $S_\alpha: S_F \Rightarrow S_G$ on spectra can be identified with the action on connected components of (6.3), so that α corresponds to a map in \mathcal{E} just when each (6.3) is surjective on connected components. This is certainly so if it is surjective on objects; it remains to show that, conversely, if (6.3) is surjective on

connected components, then it is surjective on objects. By our assumption, for each $t: y_c \rightarrow GA$, we can find a generic operation $s: y_c \rightarrow FB$ such that $\alpha_B.s$ is in the connected component of t . Since α is pointwise generic, $\alpha_B.s$ is generic in $y_c \downarrow G$, and so admits a map $f: \alpha_B.s \rightarrow t$. This says that $t = Gf.\alpha_B.s = \alpha_A.Ff.s$ so that t is the image under (6.3) of $Ff.s$, as required. \square

Corollary 6.9. *Let $U \in \mathbf{AN}_{\text{pt}}(\mathcal{P}\mathcal{C}, \mathcal{P}\mathcal{C})$ be subterminal. The category \mathbf{SH}_U of shapely U -analytic functors is equivalent to the poset of subfunctors of U 's spectrum $S_U \in \mathcal{P}\mathcal{C}$; in particular, \mathbf{SH}_U is a complete preorder, whose joins are given by unions of subfunctors of $U \in \mathbf{CAT}(\mathcal{P}\mathcal{C}, \mathcal{P}\mathcal{C})$.*

Proof. By the preceding result, the shapely U -analytic endofunctors correspond under Proposition 4.17 to the \mathcal{M} -subobjects of (S_U, E_U) in $\text{el}_{\mathcal{C}} \parallel_v \mathcal{O}(\mathcal{P}\mathcal{C})$. Any such subobject has a unique representative of the form $(p, 1): (S, E_U.\text{el } p) \rightarrow (S_U, E_U)$ for $p: S \hookrightarrow S_U$ a subfunctor inclusion. This proves the first claim; the stated form of joins in \mathbf{SH}_U follows by transporting across the equivalence $\text{el}_{\mathcal{C}} \parallel_v \mathcal{O}(\mathcal{P}\mathcal{C}) \simeq \mathbf{AN}_{\text{pt}}(\mathcal{P}\mathcal{C}, \mathcal{P}\mathcal{C})$. \square

Example 6.10. Consider the subterminal $U_{\mathcal{P}} \in \mathbf{AN}_{\text{pt}}(\mathcal{P}\mathcal{P}, \mathcal{P}\mathcal{P})$ which classifies framed $(I_{\mathcal{P}}, I_{\mathcal{P}})$ -cellular endofunctors. By Proposition 6.2, the spectrum S of $U_{\mathcal{P}}$ has $S(\star) = \{u\}$ and $S(n, m)$ the set of well-labelled elements in $\mathcal{L}(n, m)$. We will say that a subpresheaf of S is *non-degenerate* if it contains $u \in S(\star)$. Clearly, a non-degenerate subpresheaf is given by selecting arbitrary subsets $\mathcal{F}(n, m)$ of well-labelled elements from each $\mathcal{L}(n, m)$; the corresponding shapely endofunctor $F: \mathcal{P}\mathcal{P} \rightarrow \mathcal{P}\mathcal{P}$ —which we also call non-degenerate—satisfies $FA(\star) = A(\star)$ and

$$FA(n, m) = \sum_{X \in \mathcal{F}(n, m)} \mathcal{P}\mathcal{P}(|X|, A)_{/\mathfrak{S}_X} .$$

We may express this subsequently by saying that the non-degenerate F *contains* the well-labelled polygraphs in each $\mathcal{F}(n, m)$. For example, the identity endofunctor of $\mathcal{P}\mathcal{P}$ contains precisely each of the well-labelled polygraphs $\langle n, m \rangle$ of Definition 2.6(d).

Returning to the general situation, when U is a nice subterminal object of $\mathbf{AN}_{\text{pt}}(\mathcal{P}\mathcal{C}, \mathcal{P}\mathcal{C})$, the composition monoidal structure on \mathbf{AN}_U induces by way of Proposition 6.7 the following binary operation on \mathbf{SH}_U .

Definition 6.11. Let $U \in \mathbf{AN}_{\text{pt}}(\mathcal{P}\mathcal{C}, \mathcal{P}\mathcal{C})$ be nice. For any $F, G \in \mathbf{SH}_U$, we let $F \cdot G \in \mathbf{SH}_U$ be the pointwise monic image of the unique $u: FG \rightarrow U$ in \mathbf{AN}_U :

$$\begin{array}{ccc} & F \cdot G & \\ & \nearrow & \nwarrow \\ FG & \xrightarrow{u} & U \end{array} .$$

The following lemma describes the basic properties of this operation.

Lemma 6.12. *Let $U \in \mathbf{AN}_{\text{pt}}(\mathcal{P}\mathcal{C}, \mathcal{P}\mathcal{C})$ be nice. The assignment $F, G \mapsto F \cdot G$ defines a monotone map $\mathbf{SH}_U \times \mathbf{SH}_U \rightarrow \mathbf{SH}_U$ which satisfies:*

$$F \cdot \text{id} \cong F \quad \text{id} \cdot G \cong G \quad \text{and} \quad (F \cdot G) \cdot H \leq F \cdot (G \cdot H) .$$

Moreover, each $(-) \cdot G: \mathbf{SH}_U \rightarrow \mathbf{SH}_U$ preserves joins, and if U is finitary, then each $F \cdot (-)$ preserves directed joins.

Proof. Monotonicity and the first two displayed equations are obvious. For the third, consider the hexagon left below in $\mathbf{AN}_{\text{pt}}(\mathcal{P}\mathcal{C}, \mathcal{P}\mathcal{C})$; the indicated arrows are pointwise epimorphic or pointwise monomorphic, whence by orthogonality there is a filler as displayed:

$$\begin{array}{ccc}
 & FGH & \\
 \swarrow & & \searrow \\
 (F \cdot G)H & & F(G \cdot H) \\
 \downarrow & & \downarrow \\
 (F \cdot G) \cdot H & \dashrightarrow & F \cdot (G \cdot H) \\
 \swarrow & & \searrow \\
 & U &
 \end{array}
 \qquad
 \begin{array}{ccc}
 & \Sigma_i F_i G & \\
 \swarrow & & \searrow \\
 (\bigvee_i F_i)G & & \Sigma_i (F_i \cdot G) \\
 \downarrow & & \downarrow \\
 (\bigvee_i F_i) \cdot G & \dashrightarrow \cong \dashrightarrow & \bigvee_i (F_i \cdot G) \\
 \swarrow & & \searrow \\
 & U &
 \end{array}$$

Next we show that $(-) \cdot G$ preserves joins of shapely functors. Let $\bigvee_i F_i$ be any such join; since it is computed as a union of subfunctors of U , the induced transformation $\Sigma_i F_i \rightarrow \bigvee_i F_i$ in $\mathbf{CAT}(\mathcal{P}\mathcal{C}, \mathcal{P}\mathcal{C})$ is epimorphic, whence also its precomposition $\Sigma_i F_i G \rightarrow (\bigvee_i F_i)G$. Thus in the hexagon right above, each edge is pointwise epi or mono as indicated, so that by orthogonality we induce an isomorphism $(\bigvee_i F_i) \cdot G \cong \bigvee_i (F_i \cdot G)$ as indicated.

Suppose now that U is finitary; by Remark 4.22, any $F \in \mathbf{SH}_U$ is then also finitary. Now any directed join $\bigvee_i G_i$ in \mathbf{SH}_U , being a union of subfunctors of U , may be computed as the colimit in $\mathbf{CAT}(\mathcal{P}\mathcal{C}, \mathcal{P}\mathcal{C})$ of the filtered diagram of subfunctor inclusions. Because any $F \in \mathbf{SH}_U$ is finitary, it will preserve this colimit, so that the induced map $\Sigma_i F G_i \rightarrow F(\bigvee_i G_i)$ in $\mathbf{CAT}(\mathcal{P}\mathcal{C}, \mathcal{P}\mathcal{C})$ is pointwise epimorphic. The argument of the previous paragraph now carries over *mutatis mutandis* to show that $F \cdot (\bigvee_i G_i) \cong \bigvee_i (F \cdot G_i)$ as required. \square

Proposition 6.13. *Let $U \in \mathbf{AN}_{\text{pt}}(\mathcal{P}\mathcal{C}, \mathcal{P}\mathcal{C})$ be finitary and nice. The forgetful $\mathbf{SHM}_U \rightarrow \mathbf{SH}_U$ is a reflective inclusion of preorders, whose image comprises those $F \in \mathbf{SH}_U$ with $\text{id} \leq F$ and $F \cdot F \leq F$. The left adjoint, giving the free shapely monad on $F \in \mathbf{SH}_U$ is defined by:*

$$F \mapsto \bar{F} = \bigvee_{n \in \mathbb{N}} (\text{id} \vee F)^n$$

where here $F^0 = \text{id}$ and $F^{n+1} = F \cdot F^n$.

Proof. The only non-trivial point is the verification that \bar{F} is indeed a reflection of F into \mathbf{SHM}_U . First, we have $\text{id} = (\text{id} \vee F)^0 \leq \bar{F}$ and $\bar{F} \cdot \bar{F} \leq \bar{F}$, since

$$\bar{F} \cdot \bar{F} \cong \bigvee_n (\text{id} \vee F)^n \cdot \bar{F} \cong \bigvee_{n,m} (\text{id} \vee F)^n \cdot (\text{id} \vee F)^m \leq \bigvee_{n,m} (\text{id} \vee F)^{(n+m)} \leq \bar{F}$$

where the first two equalities use cocontinuity of $(-) \cdot \bar{F}$ and directed cocontinuity of each $(\text{id} \vee F)^n \cdot (-)$ (noting that the join defining \bar{F} is indeed directed) and the third inequality uses repeatedly $(F \cdot G) \cdot H \leq F \cdot (G \cdot H)$. So $\bar{F} \in \mathbf{SHM}_U$; moreover, if $G \in \mathbf{SHM}_U$ satisfies $F \leq G$, then since $\text{id} \leq G$ we have $(\text{id} \vee F) \leq G$; furthermore, if $(\text{id} \vee F)^n \leq G$, then

$$(\text{id} \vee F)^{(n+1)} = (\text{id} \vee F) \cdot (\text{id} \vee F)^n \leq G \cdot G \leq G$$

so that by induction on n we have $(\text{id} \vee F)^n \leq G$ for all n and so, finally, that $\bar{F} \leq G$. This proves that \bar{F} is a reflection of F into \mathbf{SHM}_U as desired. \square

6.3. Polycategories, properads and PROPs. We are now ready to apply the preceding theory to our motivating examples. We concentrate on exhibiting the “free polycategory” monads on \mathcal{PP} and \mathcal{PP}_s as free shapely monads, but also indicate how this extends to the cases of properads and PROPs.

We begin in the non-symmetric case \mathcal{PP} by describing a non-degenerate shapely endofunctor $\Sigma_{\mathcal{P}}$ which encodes the basic polycategorical wiring operations; for this, it suffices by Example 6.10 to describe which well-labelled polygraphs $\Sigma_{\mathcal{P}}$ will contain. We make use of the operations on polygraphs of Definition 2.6 above. The elements $\text{id} \in \mathcal{L}(1, 1)$ and $\langle n, m \rangle \in \mathcal{L}(n, m)$ in parts (a) and (d) of this definition are well-labelled, and that the operations $(-)_j \bullet_i (-)$ and $\psi \cdot (-) \cdot \varphi$ of parts (b) and (c) preserve well-labelledness; so it makes sense to give:

Definition 6.14. Let $\Sigma_{\mathcal{P}}$ be the non-degenerate shapely $U_{\mathcal{P}}$ -analytic endofunctor of \mathcal{PP} which contains the following well-labelled polygraphs:

- (i) $\text{id} \in \mathcal{L}(1, 1)$;
- (ii) $\psi \cdot \langle n, m \rangle \cdot \varphi$ for each n, m and permutations $\varphi \in \mathfrak{S}_n$ and $\psi \in \mathfrak{S}_m$;
- (iii) $\langle p, q \rangle_j \bullet_i \langle n, m \rangle \in \mathcal{L}(n + p - 1, m + q - 1)$ for all n, m, p, q and all suitable indices i, j .

Theorem 6.15. *The free shapely monad on the shapely $U_{\mathcal{P}}$ -analytic endofunctor $\Sigma_{\mathcal{P}}$ is the “free polycategory” monad on \mathcal{PP} ; similarly, the monads for properads and PROPs are free shapely monads on \mathcal{PP} .*

Proof. Since $\Sigma_{\mathcal{P}}$ contains each of the shapes $\langle n, m \rangle$, we have by Example 6.10 that $\text{id} \subset \Sigma_{\mathcal{P}}$; so by the formula of Proposition 6.13, the free shapely monad on $\Sigma_{\mathcal{P}}$ is given by $\bigvee_n (\Sigma_{\mathcal{P}})^n$. To compute this, we first calculate for any non-degenerate shapely $U_{\mathcal{P}}$ -analytic endofunctor F the composite $\Sigma_{\mathcal{P}} \cdot F$. Since F is non-degenerate, it is by Example 6.10 specified by families of well-labelled polygraphs $\mathcal{F}(n, m) \subset \mathcal{L}(n, m)$; $\Sigma_{\mathcal{P}} \cdot F$ is then also non-degenerate, and so it will suffice to determine the well-labelled polygraphs which it contains. These polygraphs correspond to generic operations of $\Sigma_{\mathcal{P}} \cdot F$ at stage $y_{(n, m)}$, and by Definition 6.11 and Proposition 6.8, such operations are precisely the images of the generic operations of $\Sigma_{\mathcal{P}} F$ at stage $y_{(n, m)}$ under the unique pointwise analytic $\Sigma_{\mathcal{P}} F \rightarrow U_{\mathcal{P}}$; so it will suffice to compute these.

Now, by Proposition 4.23, any generic operation $v: y_{(n, m)} \rightarrow \Sigma_{\mathcal{P}} F A$ is the composite of a $\Sigma_{\mathcal{P}}$ -generic operation $s: y_{(n, m)} \rightarrow \Sigma_{\mathcal{P}} B$ and an F -generic operation $t: B \rightarrow F A$. The first possibility is that

$$v = y_{(1, 1)} \xrightarrow{s} \Sigma_{\mathcal{P}}(y_{\star}) \xrightarrow{\Sigma_{\mathcal{P}}(t)} \Sigma_{\mathcal{P}} F(y_{\star})$$

where s corresponds to $\text{id} \in \mathcal{L}(1, 1)$. This v is sent by $\Sigma_{\mathcal{P}} F \rightarrow U_{\mathcal{P}}$ to a well-labelled polygraph $X \in \mathcal{L}(1, 1)$ with $|X| = y_{\star}$, which clearly forces $X = \text{id}$. The next possibility is that

$$v = y_{(n, m)} \xrightarrow{s} \Sigma_{\mathcal{P}}(y_{(n, m)}) \xrightarrow{\Sigma_{\mathcal{P}}(t)} \Sigma_{\mathcal{P}} F(|X|)$$

where s corresponds to $\psi \cdot \langle n, m \rangle \cdot \varphi \in \mathcal{L}(n, m)$, and t corresponds to some well-labelled $X \in \mathcal{F}(n, m)$. The composite v is sent by $\Sigma_{\mathcal{P}} F \rightarrow U_{\mathcal{P}}$ to a well-labelled $Y \in \mathcal{L}(n, m)$ with underlying polygraph $|X|$; to calculate the leaf labellings

$\ell_1^Y, \dots, \ell_n^Y$, we apply (4.7) and Remark 4.15, which tell us that they arise by taking generic covers as to the left in:

$$\begin{array}{ccc}
y_\star & \xrightarrow{y_{\sigma_i}} & Y_{(n,m)} \\
\downarrow \widetilde{v \cdot y_{\sigma_i}} & & \downarrow v \\
\Sigma_{\mathcal{P}} F(y_\star) & \xrightarrow{\Sigma_{\mathcal{P}} F(\ell_i^Y)} & \Sigma_{\mathcal{P}} F(|X|)
\end{array}
\qquad
\begin{array}{ccc}
y_\star & \xrightarrow{y_{\sigma_i}} & y_\star \\
\downarrow \widetilde{s \cdot y_{\sigma_i}} & & \downarrow s \\
\Sigma_{\mathcal{P}}(y_\star) & \xrightarrow{\Sigma_{\mathcal{P}}(y_{\sigma_{\varphi(i)}})} & \Sigma_{\mathcal{P}}(Y_{(n,m)}) \\
\downarrow \Sigma_{\mathcal{P}}(t \cdot \widetilde{y_{\sigma_{\varphi(i)}}}) & & \downarrow \Sigma_{\mathcal{P}}(t) \\
\Sigma_{\mathcal{P}} F(y_\star) & \xrightarrow{\Sigma_{\mathcal{P}} F(\ell_{\varphi(i)}^X)} & \Sigma_{\mathcal{P}} F(|X|) .
\end{array}$$

But from the given forms of s and t , we have generic covers as to the right, and so must have that $\ell_i^Y = \ell_{\varphi(i)}^X$. The same argument shows that $r_j^Y = r_{\psi^{-1}(j)}^X$, and so we conclude that in fact $Y = \psi \cdot X \cdot \varphi$. The final possibility is that

$$v = Y_{(n+p-1, m+q-1)} \xrightarrow{s} \Sigma_{\mathcal{P}}(Y_{(p,q)} \bullet_i Y_{(n,m)}) \xrightarrow{\Sigma_{\mathcal{P}}(t)} \Sigma_{\mathcal{P}} F A$$

where s corresponds to $\langle p, q \rangle \bullet_i \langle n, m \rangle \in \mathcal{L}(n+p-1, m+q-1)$. As for the F -generic t , note that the map $y_{\sigma_j} : y_\star \rightarrow Y_{(p,q)}$ is a relative finite $I_{\mathcal{P}}$ -complex; whence by virtue of the pushout (2.6) and Proposition 5.9, t must arise from a pointwise pushout in $\mathcal{P} \downarrow F$ of the form:

$$\begin{array}{ccccc}
& & y_{\sigma_j} & y_\star & \xrightarrow{y_{\tau_i}} & Y_{(n,m)} \\
& & \swarrow & \downarrow & \swarrow & \downarrow t_1 \\
Y_{(p,q)} & \xrightarrow{y_{\sigma_j}} & y_\star & \xrightarrow{y_{\tau_i}} & Y_{(n,m)} \\
& & \downarrow t_0 & & \downarrow t_1 \\
& & F y_\star & \xrightarrow{F r_i^X} & F |X| \\
& & \downarrow t_2 & & \downarrow t \\
F |Y| & \xrightarrow{F \ell_j^Y} & F y_\star & \xrightarrow{F r_i^X} & F |X| \\
& & \downarrow & & \downarrow \\
& & F A & & F A
\end{array}$$

where t_0 is the unique F -generic operation at stage y_\star , and t_1 and t_2 are F -generic operations corresponding to well-labelled polygraphs $X \in \mathcal{F}(n, m)$ and $Y \in \mathcal{F}(p, q)$. Since the bottom face is a pushout, we conclude that the generic v must correspond to a well-labelled polygraph $Z \in \mathcal{L}(n+p-1, m+q-1)$ with $|Z| = |Y \bullet_i X|$; now a similar calculation to before shows that the labellings of Z are such that, in fact, we have $Z = Y \bullet_i X$.

In sum, we have now shown that, for any non-trivial shapely $U_{\mathcal{P}}$ -analytic endofunctor F containing the well-labelled polygraphs $\mathcal{F}(n, m)$, the well-labelled polygraphs contained in the shapely composite $\Sigma_{\mathcal{P}} \cdot F$ are given by:

- (i) $\text{id} \in \mathcal{L}(1, 1)$;
- (ii) $\psi \cdot X \cdot \varphi \in \mathcal{L}(n, m)$ for all $X \in \mathcal{F}(n, m)$, $\varphi \in \mathfrak{S}_n$ and $\psi \in \mathfrak{S}_m$;
- (iii) $Y \bullet_i X \in \mathcal{L}(n+p-1, m+q-1)$ for all $X \in \mathcal{F}(n, m)$, $Y \in \mathcal{F}(p, q)$ and suitable indices i, j .

Consequently, the well-labelled polygraphs contained in the free shapely monad $\bigvee_n (\Sigma_{\mathcal{P}})^n$ are those obtained by closing the $\langle n, m \rangle$'s under the operations (a)–(c) of Definition 2.6, and by definition, these are precisely the finite labelled

polycategorical trees $\mathcal{T}(n, m)$. It follows from Example 6.10 that the free shapely monad T on $\Sigma_{\mathcal{P}}$ is given by $TX(\star) = X(\star)$ and

$$TX(n, m) = \sum_{T \in \mathcal{T}(n, m)} \mathcal{P}\mathcal{P}(|T|, X) / \mathfrak{S}_T = \sum_{T \in \mathcal{T}(n, m)} \mathcal{P}\mathcal{P}(|T|, X)$$

where the second equality follows from the observation that a labelled polycategorical tree has *no* non-trivial label-preserving automorphisms. Comparing this with the formula of Proposition 2.9 gives the result.

Adapting this result to the cases of properads and PROPS is almost trivial in our framework; all we need to do is to replace the closure operations of Definition 2.6 which defined the class of polycategorical trees with the corresponding closure operations defining the properadic graphs or the graphs for PROPS. Thus, for example, the monad for properads on the category $\mathcal{P}\mathcal{P}$ arises as the free shapely monad on the shapely endofunctor specified by the well-labelled polygraphs

$$\text{id}, \quad \psi \cdot \langle n, m \rangle \cdot \varphi \quad \text{and} \quad \langle p, q \rangle_{I \bullet J} \langle n, m \rangle .$$

The case of PROPS proceeds similarly. □

The argument just given for the free polycategory monad on $\mathcal{P}\mathcal{P}$ applies equally well to the free polycategory monad on $\mathcal{P}\mathcal{P}_s$. By adapting Example 6.10, we see that the non-trivial shapely endofunctors of $\mathcal{P}\mathcal{P}_s$ are specified by giving subsets $\mathcal{F}_s(n, m) \subset \mathcal{L}_s(n, m)$ of well-labelled finite symmetric trees; so we can define a shapely endofunctor $\Sigma_{\mathcal{P}_s}$ by requiring it to contain $\text{id} \in \mathcal{L}_s(1, 1)$ and each $\langle p, q \rangle_{j \bullet i} \langle n, m \rangle \in \mathcal{L}_s(n + p - 1, m + q - 1)$. Now following the precise same argument as in Theorem 6.15 gives:

Theorem 6.16. *The free shapely monad on the shapely $U_{\mathcal{P}_s}$ -analytic endofunctor $\Sigma_{\mathcal{P}_s}$ is the “free polycategory” monad on $\mathcal{P}\mathcal{P}_s$; similarly, the monads for properads and PROPS are free shapely monads on $\mathcal{P}\mathcal{P}_s$.*

REFERENCES

- [1] ABBOTT, M., ALTENKIRCH, T., GHANI, N., AND MCBRIDE, C. Constructing polymorphic programs with quotient types. In *Mathematics of program construction*, vol. 3125 of *Lecture Notes in Computer Science*. Springer, 2004, pp. 2–15.
- [2] BLUTE, R. F., COCKETT, J. R. B., SEELY, R. A. G., AND TRIMBLE, T. H. Natural deduction and coherence for weakly distributive categories. *Journal of Pure and Applied Algebra* 113 (1996), 229–296.
- [3] BONCHI, F., SOBOCIŃSKI, P., AND ZANASI, F. Full abstraction for signal flow graphs. In *Principles of Programming Languages* (2015).
- [4] BURRONI, A. Higher-dimensional word problems with applications to equational logic. *Theoretical Computer Science* 115, 1 (1993), 43–62.
- [5] CARBONI, A., AND JOHNSTONE, P. Connected limits, familial representability and Artin glueing. *Mathematical Structures in Computer Science* 5, 4 (1995), 441–459.
- [6] DIERS, Y. Spectres et localisations relatifs à un foncteur. *Comptes rendus hebdomadaires des séances de l’Académie des sciences* 287, 15 (1978), 985–988.
- [7] FIORE, M. Analytic functors between presheaf categories over groupoids. *Theoretical Computer Science* 546 (2014), 120–131.
- [8] FIORE, M., GAMBINO, N., HYLAND, M., AND WINSKEL, G. The cartesian closed bicategory of generalised species of structures. *Journal of the London Mathematical Society* 77, 1 (2008), 203–220.
- [9] FONG, B. Causal theories: A categorical perspective on bayesian networks. Master’s thesis, University of Oxford, 2012.

- [10] FREYD, P. J., AND KELLY, G. M. Categories of continuous functors I. *Journal of Pure and Applied Algebra* 2, 3 (1972), 169–191.
- [11] GIRARD, J.-Y. Linear logic. *Theoretical Computer Science* 50, 1 (1987), 1–101.
- [12] HASEGAWA, R. Two applications of analytic functors. *Theoretical Computer Science* 272, 1-2 (2002), 113–175.
- [13] HOVEY, M. *Model categories*, vol. 63 of *Mathematical Surveys and Monographs*. American Mathematical Society, 1999.
- [14] JENSEN, O. H., AND MILNER, R. Bigraphs and mobile processes (revised). Technical report TR580, University of Cambridge, 2004.
- [15] JOHNSON, M., AND WALTERS, R. F. C. Algebra objects and algebra families for finite limit theories. *Journal of Pure and Applied Algebra* 83, 3 (1992), 283–293.
- [16] JOYAL, A. Foncteurs analytiques et espèces de structures. In *Combinatoire énumérative (Montreal, 1985)*, vol. 1234 of *Lecture Notes in Mathematics*. Springer, 1986, pp. 126–159.
- [17] JOYAL, A., AND STREET, R. The geometry of tensor calculus. *Advances in Mathematics* 88, 1 (1991), 55–112.
- [18] KELLY, G. M. *Basic concepts of enriched category theory*, vol. 64 of *London Mathematical Society Lecture Note Series*. Cambridge University Press, 1982. Republished as: *Reprints in Theory and Applications of Categories* 10 (2005).
- [19] KELLY, G. M., AND MAC LANE, S. Coherence in closed categories. *Journal of Pure and Applied Algebra* 1, 1 (1971), 97–140.
- [20] KOCK, J. Polynomial functors and trees. *International Mathematics Research Notices*, 3 (2011), 609–673.
- [21] KOCK, J. Graphs, hypergraphs, and properads. *Collectanea Mathematica* 67, 2 (2016), 155–190.
- [22] LAFONT, Y. Interaction nets. In *Principles of Programming Languages* (1990), ACM.
- [23] LAMBEK, J. Deductive systems and categories. II. Standard constructions and closed categories. In *Category Theory, Homology Theory and their Applications, I*, no. 42 in *Lecture Notes in Mathematics*. Springer, 1969, pp. 76–122.
- [24] LAMBEK, J. From categorial grammar to bilinear logic. In *Substructural logics (Tübingen, 1990)*, vol. 2 of *Studies in Logic and Computation*. Oxford University Press, 1993, pp. 207–237.
- [25] LAWVERE, F. W. *Functorial semantics of algebraic theories*. PhD thesis, Columbia University, 1963. Republished as: *Reprints in Theory and Applications of Categories* 5 (2004).
- [26] LEINSTER, T. *Higher operads, higher categories*, vol. 298 of *London Mathematical Society Lecture Note Series*. Cambridge University Press, 2004.
- [27] MAC LANE, S. Categorical algebra. *Bulletin of the American Mathematical Society* 71 (1965), 40–106.
- [28] MARKL, M., SHNIDER, S., AND STASHEFF, J. *Operads in algebra, topology and physics*, vol. 96 of *Mathematical Surveys and Monographs*. American Mathematical Society, Providence, RI, 2002.
- [29] MAY, J. P. *The geometry of iterated loop spaces*, vol. 271 of *Lecture Notes in Mathematics*. Springer, 1972.
- [30] MCCLURE, J. E., AND SMITH, J. H. A solution of Deligne’s Hochschild cohomology conjecture. In *Recent progress in homotopy theory (Baltimore, 2000)*, vol. 293 of *Contemporary Mathematics*. American Mathematical Society, 2002, pp. 153–193.
- [31] SELINGER, P. A survey of graphical languages for monoidal categories. In *New structures for physics*, vol. 813 of *Lecture Notes in Physics*. Springer, Heidelberg, 2011, pp. 289–355.
- [32] SZABO, M. E. Polycategories. *Communications in Algebra* 3, 8 (1975), 663–689.
- [33] SZABO, M. E. The logic of closed categories. *Notre Dame Journal of Formal Logic* 18, 3 (1977), 441–457.
- [34] TAMBARA, D. Finite categories with pushouts. *Theory and Applications of Categories* 30 (2015), 1017–1031.
- [35] VALLETTE, B. A Koszul duality for PROPs. *Transactions of the American Mathematical Society* 359, 10 (2007), 4865–4943.

- [36] WEBER, M. *Symmetric Operads for Globular Sets*. PhD thesis, Macquarie University, 2001.
- [37] WEBER, M. Generic morphisms, parametric representations and weakly Cartesian monads. *Theory and Applications of Categories* 13 (2004), 191–234.

DEPARTMENT OF MATHEMATICS, MACQUARIE UNIVERSITY, NSW 2109, AUSTRALIA
E-mail address: `richard.garner@mq.edu.au`

UNIV. SAVOIE MONT BLANC, CNRS, LAMA, F-73000 CHAMBÉRY, FRANCE
E-mail address: `tom.hirschowitz@univ-smb.fr`